

900 SERIES ROLLING SERVICE DOORS

RELIABLE AND DURABLE ROLLING SERVICE DOORS

The Wayne-Dalton 900 Series rolling service door is ideal for jobs where an economical solution for durability and strength is needed. The 900 Series offers flexibility in substrate materials with choices of 24, 22, or 20-gauge galvanized steel, stainless steel, or aluminum.

Color options range from our five standard factory-finish colors to a full range of 180 RAL powder coat choices.



COMMERCIAL DOORS & OPERATORS

- SIZES UP TO 16' WIDE AND 16' HIGH
- MAX STEEL GAUGE = 20
- 2" FLAT AND CURVED SLATS
- DURABLE & ECONOMICAL

ROLLING SERVICE DOORS

900 SERIES

Popular in both interior and exterior applications, the Wayne-Dalton 900 Series rolling service door features a galvanized, pre-painted curtain of minimum 24-gauge steel. All 900 series doors are standard wind load rated with a minimum of 20 PSF.

Materials & Construction

Wayne-Dalton's 900 Series rolling doors are composed of curved or flat-faced slats that provide a natural water-shed, helping to reduce corrosion. The slats are designed with free-acting interlocking joints that permit easy articulation when the door coils.

The 900 Series features a strong double-angle bottom bar that reinforces the lower edge of the curtain against wind pressure and permits varied lock, astragal and safety edge options. This bottom bar is designed for easy installation and does not require fasteners protruding into the guide openings, so the bottom bar does not interfere with door operation.

Counterbalance assembly consists of a spring barrel which serves as load-carrying beam. It encases the counterbalance mechanism and provides the axis around which the curtain coils. (Deflection is limited to 0.033" per lineal foot of span.) If required, barrel rings of malleable iron or stamped steel may be provided to assure proper counterbalance. Oil-tempered, torsion-type counterbalance springs are wound from heat-treated steel, providing accuracy in balancing the door. Barrel plugs connect ends of springs to barrel and tension rod. Tension rod of steel shafting holds fixed ends of springs and carries torsional load of spring counterbalance.

Spring tension adjusting wheel is normally mounted outside the bracket on end of tension rod. Inside adjusting wheel for tight side-room applications is available in limited sizes.

The hood cover encloses the curtain coil and counterbalance mechanism. Slat hoods are available on blue, brown, beige, and white doors.

Available Options

- Secur-Vent (Flat Slat Only)
- Safety Edges
- Drop Stop Device
- Exhaust Ports
- Sloping Bottom Bars
- Powder Coated
- Motor Operators
- Cable Reels
- Mullions
- Thru-Wall Operation
- Stainless Steel or Aluminum Finishes



Slat Profiles

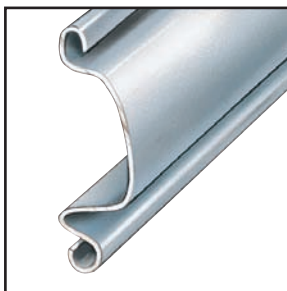

No. 2 — Curved-faced single crown slat available in up to 20-gauge steel, 20-gauge stainless steel, or up to 18-gauge B&S aluminum (mill, clear, or bronze anodized). Depth of crown: 1/2", 1 1/8" on centers.

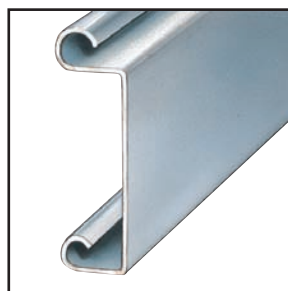

No. 17 — Flat-faced slat in up to 20-gauge steel, 20-gauge stainless steel, or 16 B&S gauge aluminum (mill, clear, or bronze anodized). Depth of crown: 1/2", 1 1/8" on centers.

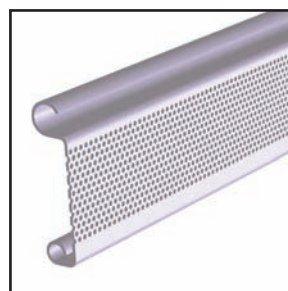

Secur-Vent® — Perforated slat provides optimal security and ventilation. Slat consists of 1/16" diameter hole offering 41% open area over length of each slat. Available in No. 17 flat slat up



No. 2 slat



No. 17 slat



Secur-Vent®

ROLLING SERVICE DOORS 900 SERIES

MANUAL OPERATION

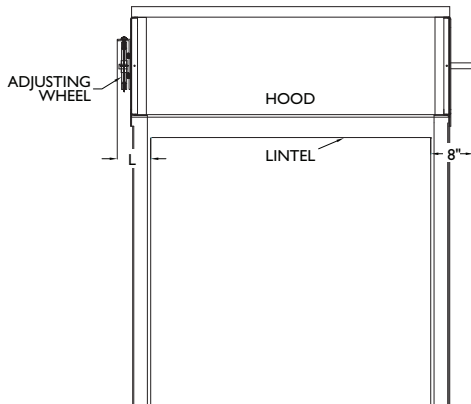

ELEVATION

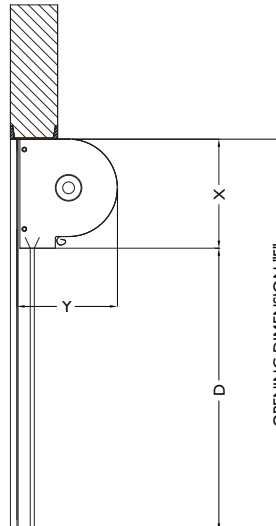

SECTION (UNDER LINTEL)

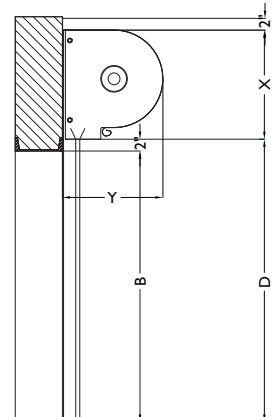

SECTION

BRACKET MOUNTED POWER UNIT

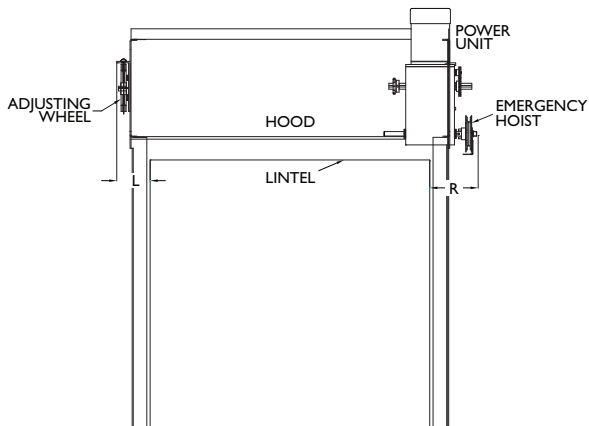

ELEVATION

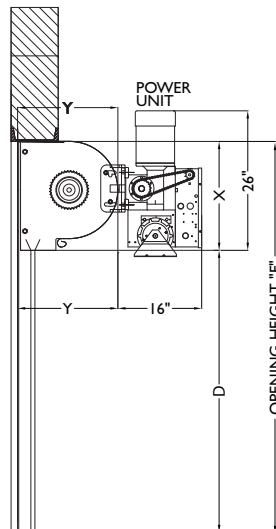

SECTION (UNDER LINTEL)

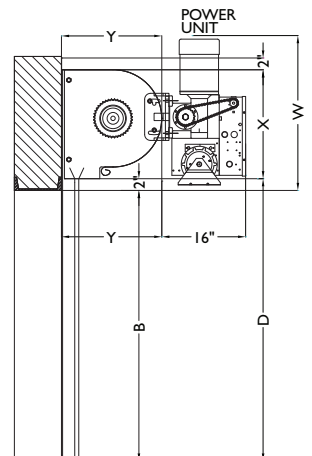

SECTION

ANGLE OR ROLLED - FACE MOUNTED TO MASONRY

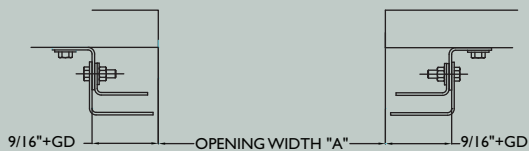

ANGLE OR ROLLED - FACE MOUNTED TO STEEL

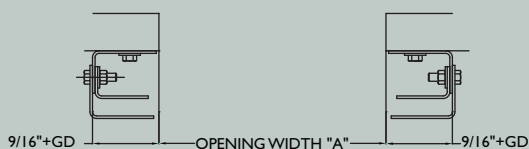

ANGLE GUIDES - MOUNTED BETWEEN JAMBS

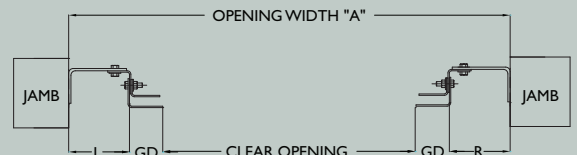

ROLLED GUIDES - MOUNTED BETWEEN JAMBS

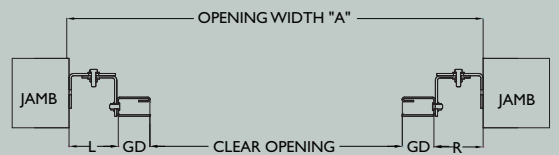

900 Series Door	
GD	WIDTH
2-5/16"	TO 16'0\"/>

ROLLING SERVICE DOORS 900 SERIES

CHAIN HOIST OPERATION

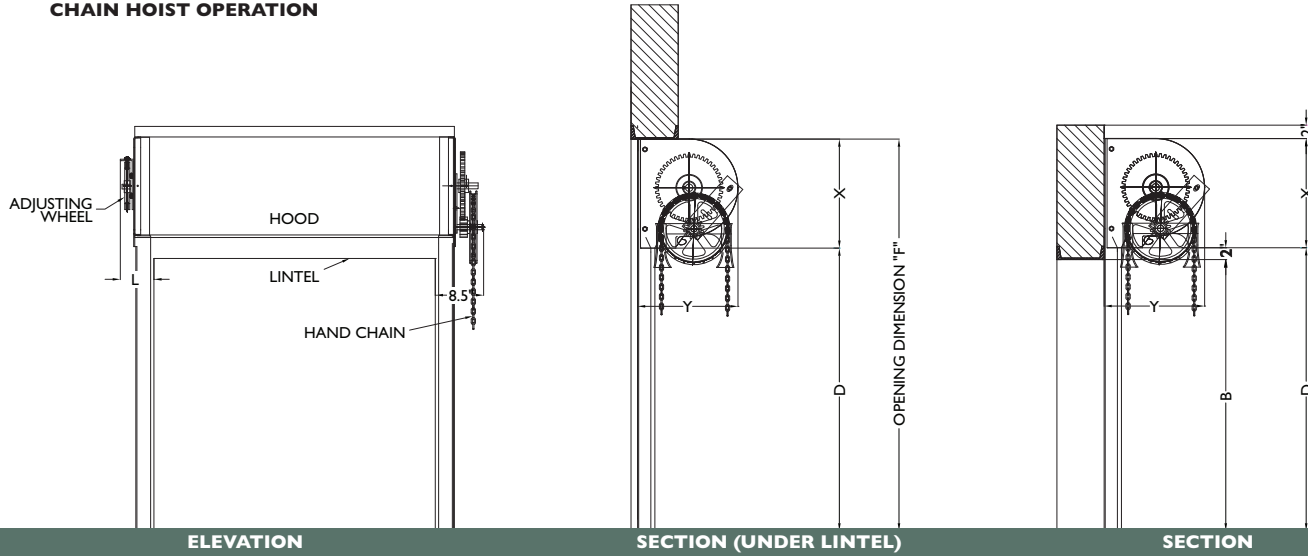

WALL MOUNTED POWER UNIT

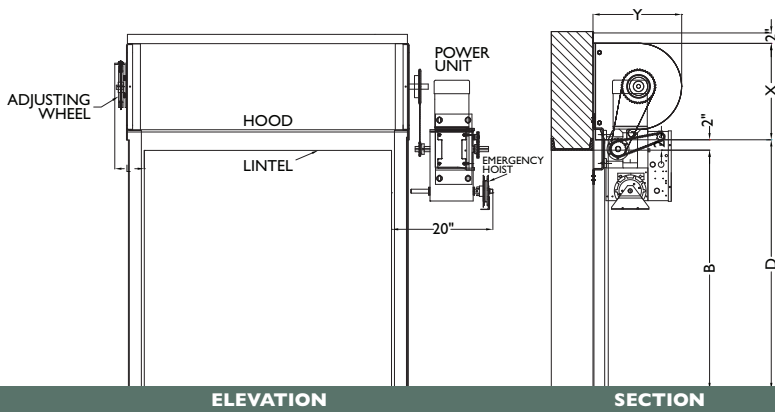

THRU-WALL MOUNTED POWER UNIT

Note: 20" sideroom required on opposite door side for power unit

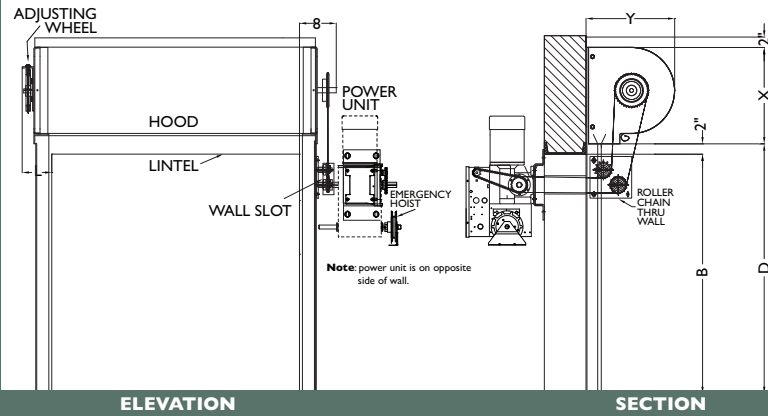

ROLLING SERVICE DOORS

900 SERIES

900 Series (Face Mounted)

Width A	HEIGHT B (OPENING HEIGHT)								
	8'8"			TO 14'1"			TO 16'0"		
	BRACKET SIZE	SIDE ROOM		BRACKET SIZE	SIDE ROOM		BRACKET SIZE	SIDE ROOM	
	X & Y	R	L	X & Y	R	L	X & Y	R	L
CHAIN HOIST OPERATED, MOTOR OPERATED									
TO 16'0"	14-1/2"	8"	6"	16-1/2"	8"	6"	18-1/2"	8"	6"
CRANK OPERATED—CONSULT FACTORY									

900 Series (Between Jambs, Under Lintel Mounted)

Width A	HEIGHT B (OPENING HEIGHT)								
	8'8"			TO 14'1"			TO 16'0"		
	BRACKET SIZE	SIDE ROOM		BRACKET SIZE	SIDE ROOM		BRACKET SIZE	SIDE ROOM	
	X & Y	R	L	X & Y	R	L	X & Y	R	L
CHAIN HOIST OPERATED, MOTOR OPERATED									
TO 16'0"	14-1/2"	4-1/4"	4-1/4"	16-1/2"	4-1/4"	4-1/4"	18-1/2"	4-1/4"	4-1/4"
CRANK OPERATED—CONSULT FACTORY									

NOTE: Dimensions are for general reference only and not for construction purposes.



COMMERCIAL DOORS & OPERATORS

ROLLING SERVICE DOORS

900 SERIES

Note to specifiers: Words in brackets indicate frequently specified and highly recommended options.

PART I – GENERAL

1.01 Work Included

- A. The opening will be equipped with Wayne-Dalton 900 Series rolling doors.

1.02 Related Work

- A. Opening preparation, miscellaneous or structural metal work, access panels, finish or field painting, field electrical wiring, wire, conduit, fuses, and disconnect switches are in the Scope of Work of other divisions or trades.

1.03 Reference Standards

- A. **ANSI/DASMA 203** – American National Standards Institute Specifications for non-rated fire rolling doors published by Door & Access Systems Manufacturers Association International.
- B. **ASTM A123** – Zinc [hot-dipped galvanized] coatings on iron and steel products.
- C. **ASTM A229** – Steel wire, oil-tempered for mechanical springs.
- D. **ASTM A-653-94** – Steel sheet, zinc-coated [galvanized] by the hot-dipped process, commercial quality.
- E. **ASTM E330** – Structural performance of exterior windows, curtain walls, and doors by uniform static air pressure difference.

1.04 Quality Assurance

- A. Rolling doors and all accessories and components required for complete and secure installations shall be manufactured as a system from one manufacturer.

1.05 Systems Description

- A. Rolling Door: Type:
Model 900
- B. Mounting: [steel][wood][masonry] jambs
- C. Operation: [manual push-up] [crank][chain hoist] [motor] [motor with chain hoist]
- D. Material: Galvanized steel with polyester finish paint

1.06 Submittals

- A. Shop Drawings: Clearly indicate the following:
 1. Design and installation details to withstand standard windload.
 2. All details required for complete operation and installation.
 3. Hardware locations.
 4. Type of metal and finish for door sections.
 5. Finish for miscellaneous components and accessories.
- B. Product Data: Indicating manufacturer's product data, and installation instructions.

1.07 Delivery, Handling, Storage

- A. Deliver products in manufacturer's original containers, dry, undamaged, seals and labels intact.
- B. Store and protect products in accordance with manufacturer's recommendations.

1.08 Warranty

- A. Standard manufacturer's one year warranty against defects in material and workmanship.

PART II – PRODUCTS

2.01 Curtain

- A. Curtain will be composed of interlocking [22, 20, gauge galvanized steel] [18 B&S aluminum] [22, 20 stainless steel] slats, roll-formed per ASTM standards and designed to withstand a 20 PSF windload. Ends of alternate slats will be fitted with metal endlocks/windlocks.
- B. Bottom bar will consist of two equal steel [stainless steel] [aluminum] angles, .121" minimum thickness, to stiffen curtain, with astragal. When required for additional security, provide [slide bolts] [cylinder locks] on the bottom bar operable from [coil side] [both sides].

2.02 Guides

- A. Guides will be roll-formed steel channel bolted to angle or structural grade, three angle assembly of steel [stainless steel] [aluminum] to form a slot of sufficient depth to retain curtains in guides to achieve 20 PSF windload standard. Guides may be provided with integral windlock bars and removable bottom bar stops.

2.03 Brackets

- A. Brackets will be of 3/16" [1/4"] minimum thick steel plates, with permanently sealed ball bearings. Designed to enclose ends of coil and provide support for counterbalance pipe at each end.

2.04 Counterbalance

- A. Curtain to be coiled on a pipe of sufficient size to carry door load with deflection not to exceed .033" per foot of door span and to be correctly balanced by helical springs, oil tempered torsion type. Cast iron barrel plugs will be used to anchor springs to tension shaft and pipe.

2.05 Hood

- A. Hood will be minimum 24-gauge [aluminum 22 gauge B&S] [galvanized] [stainless steel] sheet metal, flanged at top for attachment to header and flanged at bottom to provide longitudinal stiffness. Hood will enclose curtain coil and counterbalance mechanism.

2.06 Finish

- A. Shop coat of rust inhibitive primer on non-galvanized surfaces and operating mechanisms. Guides and bracket plates will be coated with a flat black prime paint. Aluminum finish to be [mill] [204R1 clear anodized] [bronze anodized]. Stainless steel finish available. Curtain color will be [white] [blue] [gray] [beige] [brown] [white, blue, beige, brown only available as 24 or 22 gauge]. Powder coating is available in 180 colors.

2.07 Operation

- A. Door will be operated by means of [manual, lift-up] [chain hoist with gear drive reduction] [awning crank] [wall crank box] [motor operation]. Optional [electrical] [pneumatic] sensing edge to be attached to bottom bar to [stop and reverse] the door when it contacts an object during the closing cycle.

2.08 Weatherstripping

- A. Air-Bar Extr-Tite doors will include flat slats, bottom astragal, surface guide weatherstrip, and internal hood baffle weatherstrip.

2.09 Locking

- A. [Manual lift-up doors will have interior slide-bolts suitable for padlocks by others.] [Chain-hoist door will have chain keepers suitable for padlocks by others.] [Electric-motor operation doors will lock through the operator gearing.] [Cylinder locks can be provided with the doors.]

Note: When specifying locks on electric-motor operated doors, electric interlocks should also be specified to prevent operation when lock bolts are engaged in the guides, thus preventing damage to the curtain and/or operator.

2.10 Windload

- A. Windload – minimum 20 psf per DASMA 102-2003 and as required by local codes.

PART III – EXECUTION

3.01 Installation

- A. General:
 1. Install doors in accordance with manufacturer's instructions and standards. Installation shall be by an authorized Wayne-Dalton representative.
 2. Verify that existing conditions are ready to receive rolling door work.
 3. Beginning of rolling door work means acceptance of existing conditions.
 - B. Install door complete with necessary hardware, jamb and head mold strips, anchors, inserts, hangers, and equipment supports in accordance with final shop drawings, manufacturer's instructions, and as specified herein.
 - C. Fit, align and adjust rolling door assemblies level and plumb for smooth operation.
 - D. Upon completion of final installation, lubricate, test and adjust doors to operate easily, free from warp, twist or distortion and fitting for entire perimeter.
- Note:** Architect may consider providing a schedule when more than one rolling door or opening type is required.

Because of continuing product improvements, we reserve the right to change the product specifications and designs without prior notice.

Distributed By:



COMMERCIAL DOORS & OPERATORS

For technical information, visit:

www.wayne-dalton.com/commercial

© 2008 Wayne-Dalton Corp. • One Door Drive • Mt. Hope, Ohio 44660 • 800-255-3046
Mt. Hope, OH • Dalton, OH • Trail, OH • Pensacola, FL • Portland, OR

Printed in U.S.A.
Item #333066 Revised 4/2008