

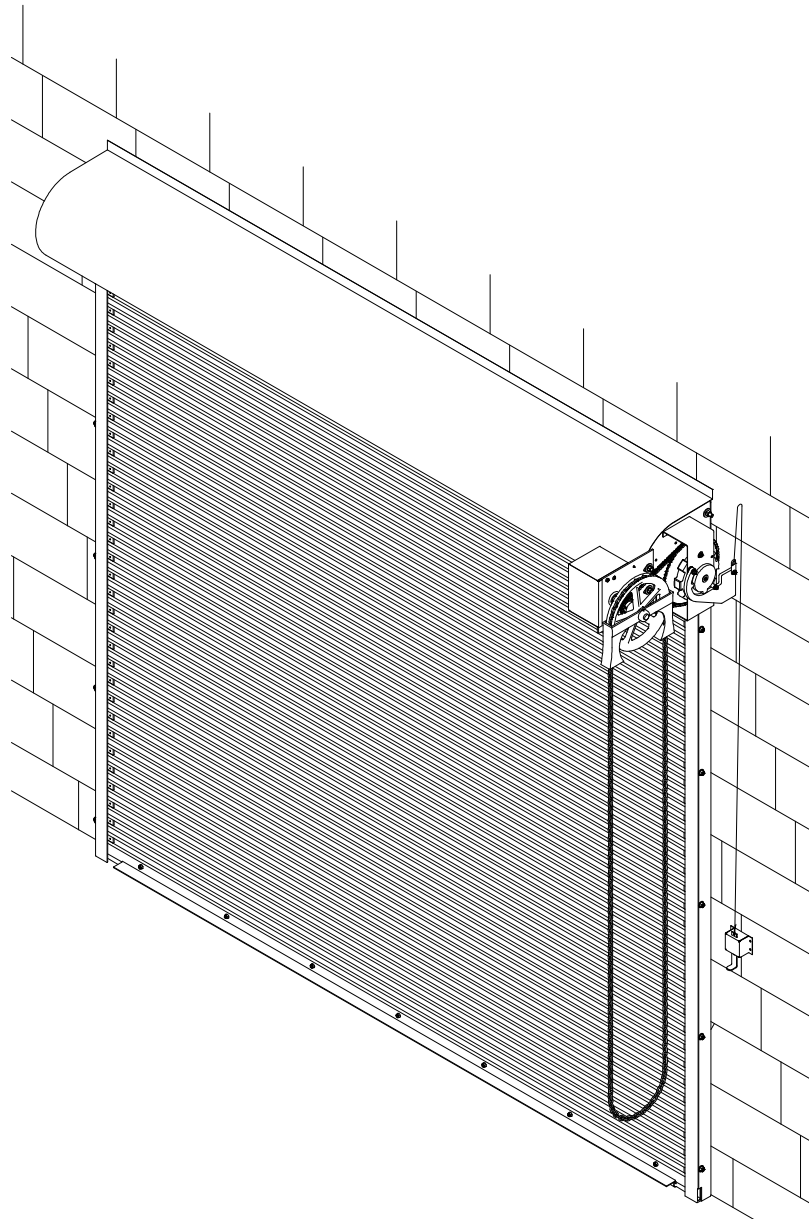

FireStar™ ROLLING STEEL FIRE DOOR

INSTALLATION INSTRUCTIONS AND OWNER'S MANUAL



IMPORTANT NOTICE!

It is required that a trained rolling fire door systems technician install and service this door. Carefully read everything in this manual before attempting installation or repairs. Pay close attention to all warnings and the important safety instructions on page 3. If in question about any of the procedures, do not perform the work. Instead, contact Wayne-Dalton Rolling Door Division Technical Services at 1-800-255-3046 for answers to your question(s). This manual must be attached to the wall in close proximity of the door, after installation is completed.

Table of Contents

	Page
Important Safety Instructions.....	3
Limited Warranty	4
Introduction.....	5
Exploded Door View and Supplied Parts List.....	6
Step 1: Opening Checks	10
Step 2: Guide Mounting	10
Step 3: Bracket to Spring Barrel Installation	15
Step 4: Barrel Assembly Installation	16
Step 5: Operator Mechanism Installation.....	17
Step 6: Curtain Assembly Installation	18
Step 7: Release Handle Mounting.....	20
Step 8: Adjusting Wheel Installation and Spring Tensioning.....	20
Step 9: Bottom Bar Stop Installation	22
Step 10: Fusible Links and Cable Routing.....	22
Step 11: Hood Installation	24
Step 12: Adjusting Chain Hoist Brake	25
Step 13: Tension Removal and Test Drop Procedure.....	25
Step 14: Miscellaneous Final Checklist	26
Optional Components (Appendix A).....	28
Service Record Chart (Appendix B).....	29
Trouble Shooting (Appendix C)	30
Compound Tension Adjuster Assembly (Appendix D)	31
Rolling Fire Door Test Drop Release Form.....	In Back
Fire Door Periodic Test Requirement.....	In Back

IMPORTANT SAFETY INSTRUCTIONS

Read the Installation Instructions/Owner's Manual carefully before attempting installation. A trained rolling fire door systems technician must install this door or make any adjustments/repairs.

1. Installation MUST comply fully with ALL provisions of NFPA 80 regulations and final approval must be obtained from the authority having jurisdiction. This is the installer's responsibility.
2. FireStar™ Fire Doors are under-balanced. Removing the roller chain from a motor operated door or tampering with the chain hoist unit on a manually operated door while the door is partially or fully open, will cause the door to freefall. This may result in severe or fatal injury.
3. Operate the door **ONLY** when it is properly adjusted and free of all obstructions.
4. The door is constantly under **EXTREME SPRING TENSION**. DO NOT attempt any adjustments, repairs, alterations or removal of any part of this door, **ESPECIALLY TO SPRINGS OR PARTS UNDER SPRING TENSION**. Such work must **ONLY** be performed by a trained rolling fire door systems technician.
5. Do not allow children to play near the door. Children could get caught between the door and the floor, causing severe or fatal injury.
6. To avoid possible severe or fatal injury, DO NOT stand in the open doorway or walk through the doorway while the door is moving.
7. Should the door become difficult to operate or completely inoperative, it is recommended that a trained rolling fire door systems technician correct the problem to prevent possible injuries or door damage.
8. Check all bolted connections monthly to insure they are secure.
9. To prevent injuries, never place hands or fingers between curtain & guides while door is moving.
10. If the building design and door installation create potential pinch points to users, owner is responsible for the installation of appropriate guarding, in compliance with OSHA regulations.
11. This manual is NOT intended to provide "take-down" instructions for existing door. Consult your local Wayne-Dalton dealer if existing door needs to be removed.
12. Thoroughly familiarize yourself with the construction codes in your region before initiating work.
13. Wear proper protective safety gear at all times when installing, repairing and/or adjusting doors.
14. Consider using a multi-person crew for installing, adjusting and/or repairing larger doors



This is the safety alert symbol. It is used to alert you to potential personal injury hazards. Obey all safety messages that follow this symbol to avoid possible injury or death.

 **WARNING**

WARNING indicates a potential hazardous situation which, if not avoided, could result in death or serious injury.

 **CAUTION**

CAUTION indicates a potentially hazardous situation which, if not avoided, may result in minor or moderate injury.

CAUTION

CAUTION used without the safety alert symbol indicates a potentially hazardous situation which, if not avoided, may result in property damage.

IMPORTANT!

IMPORTANT! indicates a required step for safe and proper door operation.

NOTE:

NOTE: indicates information assuring proper installation of the door.

HINT:

HINT: indicates a suggested step to simplify installation based on experience.

Limited Warranty

FireStar™ Rolling Steel Fire Door

Subject to the terms and conditions contained in this Limited Warranty, Wayne-Dalton Corp. ("Manufacturer") warrants the rolling steel fire door, which is described at the top of this page, for a period of **ONE (1) YEAR** from the date of installation, against any defects in material and workmanship.

The Manufacturer warrants the hardware and fittings of the above-described rolling steel fire door, for a period of **ONE (1) YEAR** from the date of installation, against any defects in material and workmanship, subject to the terms and conditions below.

The Manufacturer warrants any optional components provided with its rolling steel fire door, such as motor operators, chain hoists and release devices, for a period of **ONE (1) YEAR** from date of installation, against defects in material and workmanship, subject to the terms and conditions below.

This Limited Warranty is not transferable to any other person (even when the premises is sold), nor does it extend any benefits to any other person. As a result this Limited Warranty does NOT apply to any person who purchases the product from someone other than an authorized Wayne-Dalton dealer or distributor.

The Manufacturer will not be responsible for any damage attributable to improper storage, improper installation, any alteration of the door or its components, abuse, damage from corrosive fumes or substances, salt spray or salt water air, fire, Acts of God, failure to properly maintain and test the door, or attempt to use the door, its components or related products for other than its intended purpose and its customary usage. This Limited warranty does not cover ordinary wear.

NO WARRANTIES, EXPRESS OR IMPLIED (INCLUDING BUT NOT LIMITED TO THE WARRANTY OF MERCHANTABILITY OR FITNESS FOR A PARTICULAR PURPOSE) WILL EXTEND BEYOND THE TIME PERIOD SET FORTH IN **UNDERScoreD BOLD FACE TYPE** IN THIS LIMITED WARRANTY, ABOVE.

- Some States do not allow limitations on how long an implied warranty lasts, so the above limitations may not apply to you.

Any claim under this Limited Warranty must be made in writing, within the applicable warranty period, to the dealer from which the product was purchased. Unless the dealer is no longer in business, a written claim to the Manufacturer will be the same as if no claim had been made at all.

At the Manufacturer's option, pursuant to the dealer having notified the Manufacturer of a warranty claim, a service representative may inspect the product on site. Buyer agrees to cooperate with any representative of the Manufacturer and to give such representative full access to the product with the claimed defect and full access to the location of its installation.

If the Manufacturer determines that the claim is valid under the terms of this Limited Warranty, the Manufacturer will cause the defective product to be repaired or replaced. The decision about the manner in which the defect will be remedied will be at the discretion of the Manufacturer, subject to applicable law. THE REMEDY WILL COVER ONLY MATERIAL. THIS LIMITED WARRANTY DOES NOT COVER OTHER CHARGES, SUCH AS FIELD SERVICE LABOR FOR REMOVAL, INSTALLATION, PAINTING, SHIPPING, ETC.

Any repairs or replacements arranged by Manufacturer will be covered by (and subject to the terms, conditions, limitations and exceptions of this Limited Warranty; provided however, that the installation date for the repaired or replaced product will be deemed to be the date the original product was installed and this Limited Warranty will expire at the same time as if there had been no defect. If a claim under this limited Warranty is resolved in a manner other than described in the immediately preceding paragraph, then neither this Limited Warranty nor any other warranty from the Manufacturer will cover the repaired or replaced portion of the product.

THE REMEDIES FOR THE BUYER DESCRIBED IN THIS LIMITED WARRANTY ARE EXCLUSIVE and take the place of any other remedy. The liability of the Manufacturer, whether in contract or tort, under warranty, product liability, or otherwise, will not go beyond the Manufacturer's obligation to repair or replace, at its option, as described above. THE MANUFACTURER WILL NOT UNDER ANY CIRCUMSTANCES BE LIABLE FOR SPECIAL, INCIDENTAL, OR CONSEQUENTIAL DAMAGES, including (but not limited to) damage or loss of other property or equipment, personal injury, loss of profit or revenues, business or service interruptions, cost of capital, cost of purchase or replacement of other goods, or claims of third parties for any of the foregoing.

- Some States do not allow the exclusion or limitation of incidental or consequential damages, so the above limitation or exclusion may not apply to you.

No employee, distributor, dealer, representative, or other person has the authority to modify any term or condition contained in this Limited Warranty or to grant any other warranty on behalf of or binding on the Manufacturer and anyone's attempt to do so will be null and void.

Buyer should be prepared to verify the date of installation to the satisfaction of the Manufacturer.

The rights and obligations of the Manufacturer and Buyer under this Limited Warranty will be governed by the laws of the State of Ohio, USA, to the extent permitted by law.

- This Limited Warranty gives you specific legal rights and you may also have other rights, which may vary from State to State.

INTRODUCTION

The main function of this manual is to assist the installer in correctly installing FireStar™ Rolling Steel Fire Doors with due regard for safety, operation, and sound construction practices. NFPA 80 and local fire and building codes take precedence over any discrepancies with these installation instructions.

All Wayne-Dalton FireStar™ Rolling Steel Fire Doors follow the general installation instructions outlined in this manual. Additional installation information for each specific door shipped is found on drawings and parts lists in the hardware bag.

PREPARATION

Read the installation instructions carefully to become familiar with the names of the various components and their relationship to each other. It is essential for the installer to determine the following:

- The type of mounting to be employed(face of wall or between jambs)
- Right or left hand operation as determined from the coil side.
- Type of jamb material on site and the proper fasteners for that material.
- The opening width, opening height, head room, and side room dimensions.

MATERIAL

Inspect all doors and components for possible damage or shortage of parts, prior to leaving for the job site. Immediately report any shortages to your Wayne-Dalton customer service representative and any shipping related damage to the shipping company.

CLEARANCES

The installation drawings, supplied in the hardware bag, contain dimensional information regarding bracket size, head room, and side room requirements for each specific door. Be sure that the opening you are working on matches those dimensions. Take special note of the "C" dimension. **THE "C" DIMENSION MUST BE HELD** to ensure proper door operation. Prior to starting the installation, be sure the required clearances are available.

TOOLS

The tools recommended for proper installation will vary with each door. Commonly used tools are:

- Electric drill with 3/8" or 1/2" chuck.
- Masonry drill or impact hammer and bits.
- Chain hoist and sling for raising barrel and curtain assembly.
- Ladders and/or scaffolding.
- Cable cutters and diagonal cutters
- Wrenches, screwdrivers, hammer, level, drills, center punch, tape measure, chalk line, plumb line, vise grips or C-clamps, and a string level.
- Two hardened steel bars, 1/2" diameter and approximately 36" long
- All appropriate Personal Protection Equipment

Exploded View of FireStar™ Rolling Steel Fire Door (Left Hand Operated Door Shown) *PATENT PENDING

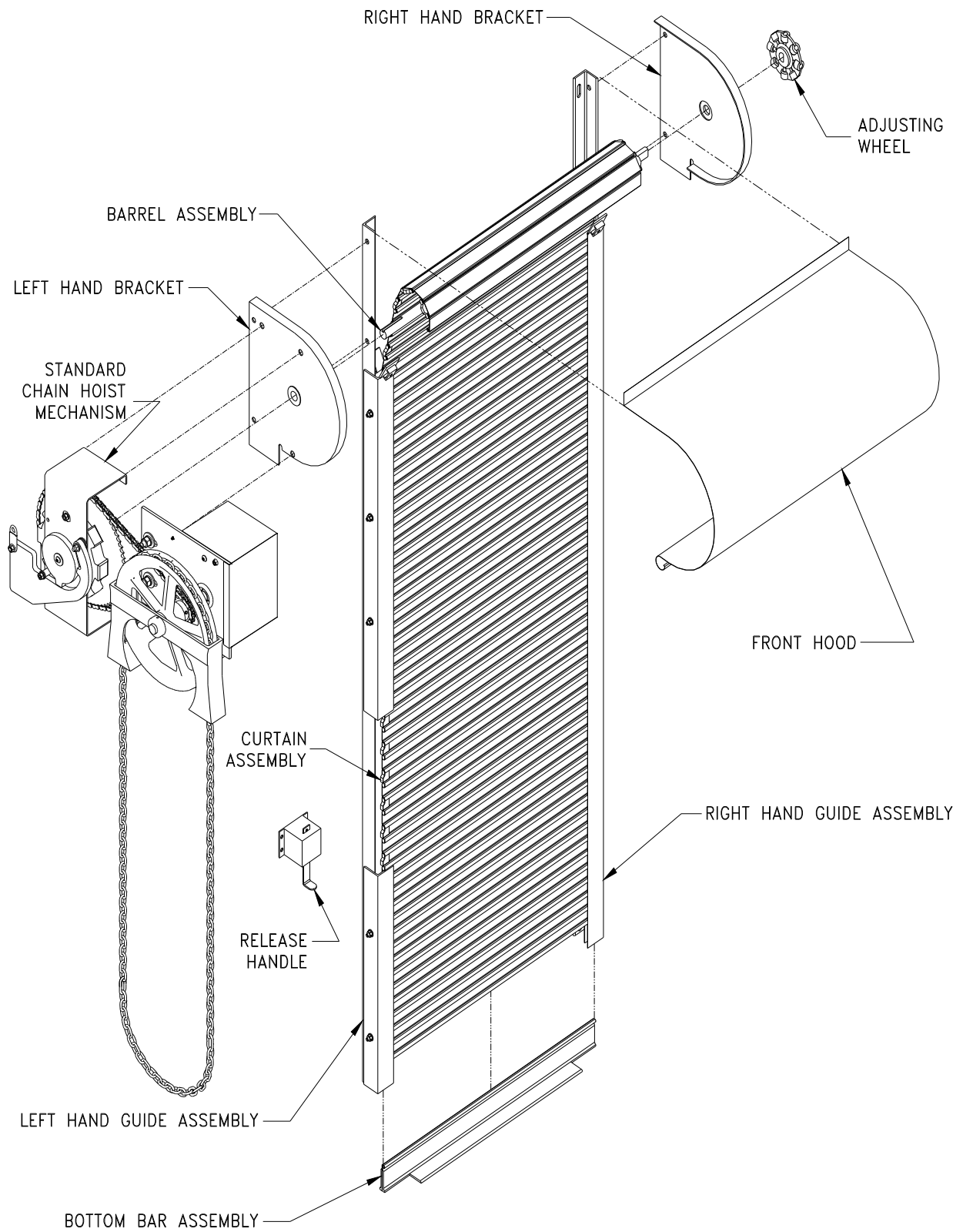

Section 1 - Supplied Parts List

Major Components and Assemblies

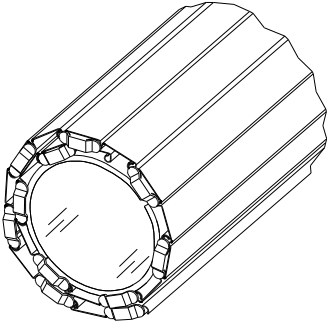
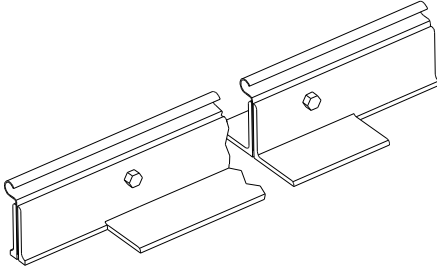
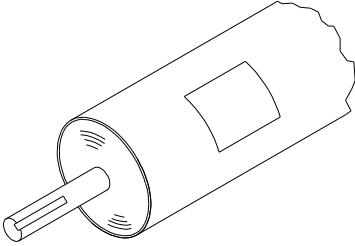
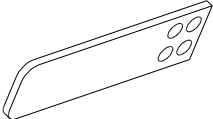
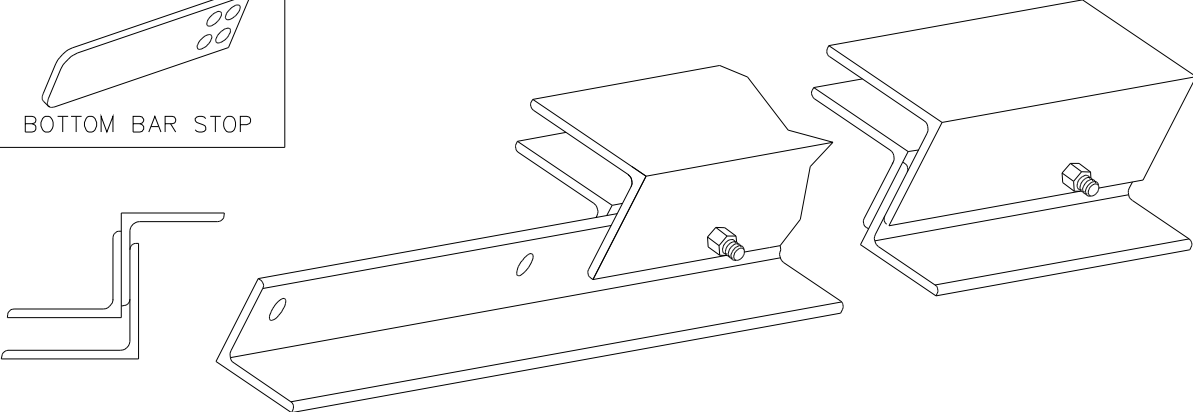
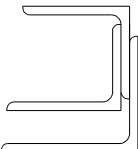
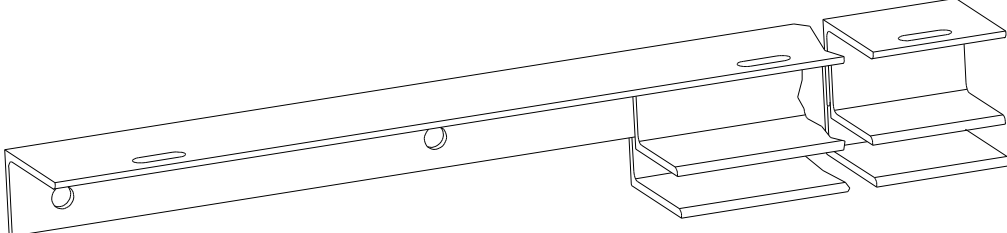
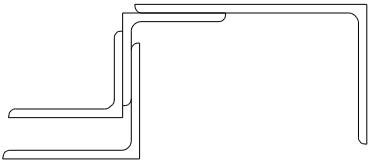
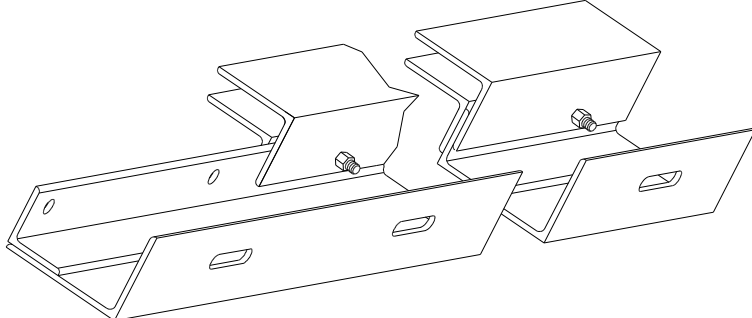
 <p>CURTAIN ASSEMBLY</p>	 <p>BOTTOM BAR ASSEMBLY</p>	 <p>BARREL ASSEMBLY</p>
 <p>BOTTOM BAR STOP</p>	 <p>MASONRY JAMB GUIDE ASSEMBLY</p>	
	 <p>STEEL JAMB GUIDE ASSEMBLY</p>	
	 <p>BETWEEN JAMBS GUIDE ASSEMBLY</p>	





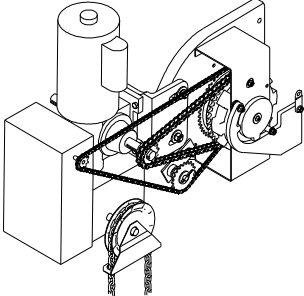
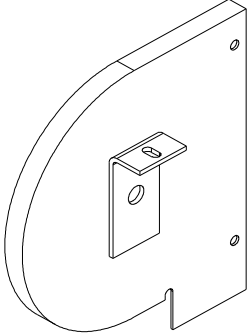
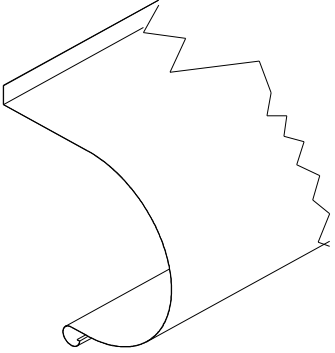
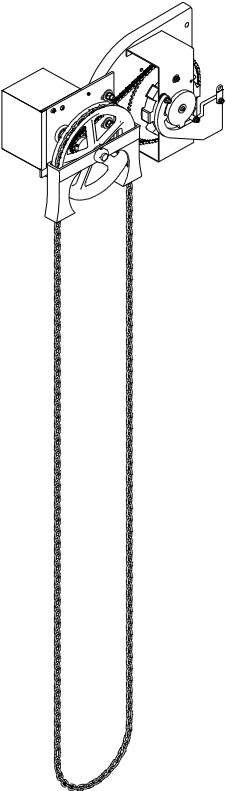
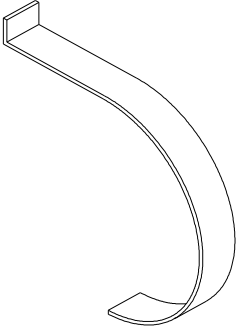
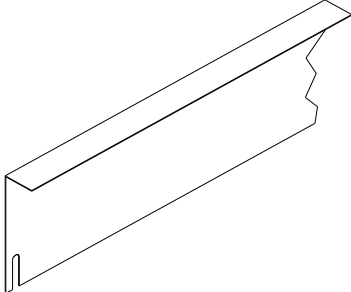
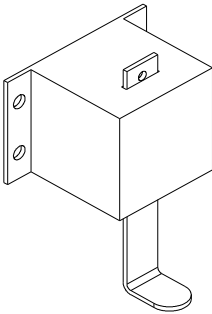
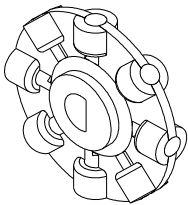

Section 2 - Supplied Parts List

Bracket Assemblies and Components

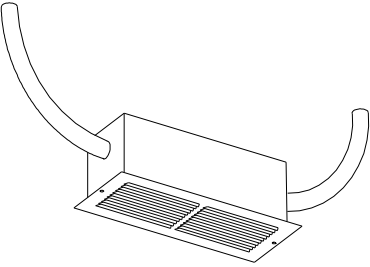
 <p style="text-align: center;">OPTIONAL MOTOR OPERATOR BRACKET ASSEMBLY</p>	 <p style="text-align: center;">ADJUSTING BRACKET ASSEMBLY</p>	 <p style="text-align: center;">FRONT HOOD</p>
 <p style="text-align: center;">STD CHAIN HOIST BRACKET ASSEMBLY</p>	 <p style="text-align: center;">HOOD STRAP (WHEN REQ'D)</p>	 <p style="text-align: center;">BACK HOOD (UNDER LINTEL ONLY)</p>
	 <p style="text-align: center;">RELEASE HANDLE</p>	 <p style="text-align: center;">ADJUSTING WHEEL</p>

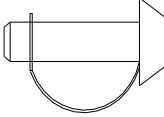
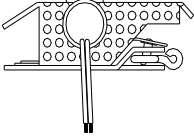
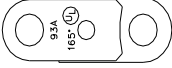
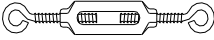
Section 3 - Supplied Parts List

Miscellaneous Components and Hardware

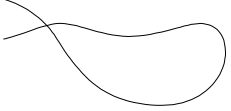
 <p>FUSE LINK HOUSING</p>	 <p>WARNING LABEL</p>	 <p>PIN</p>		
 <p>OPTIONAL CONTROL DEVICE RELEASE</p>	 <p>FUSIBLE LINK</p>			
 <p>TURNBUCKLE</p>	 <p>"S" HOOK</p>	 <p>COTTER PIN</p>	 <p>NICO PRESS FITTING</p>	 <p>FUSE CABLE</p>

Included in the bag of hardware is a packing list showing where each piece is used. Below is an example of such a list. Your list may vary in sizes and quantities shown. A ruler is printed at the bottom of this page for your convenience.

QTY	PART #	DESCRIPTION	WHERE USED
2	807-0171-04	Cotter Pin - 3/16" x 1-1/2"	AW & Drive Side
6	801-0350-05	1/2"-13 x 1-1/2" HH Cap Screw	Brackets to Guides
6	802-0004-05	1/2"-13 Hex Nut	Brackets to Guides
18	805-0100-04	3/8" x 3-3/4" Stud Anchors	Guides to Wall
5	801-1070-05	1/4"-20 x 1-1/2" RHMS	Hood to Wall
5	805-0129-04	1/4" x 1" Expansion Shield	Hood to Wall
5	804-0002-05	1/4" Flat Washer	Hood to Wall
10	803-1807-05	1/4" x 1/2" Self-Tapping Screws	Hood to Brackets/Strap
4	801-2808-05	3/8"-16 x 3/4" Hex Hd Grade 5	BB Stops to Guides
10	801-0274-05	5/16"-18 x 1" HHCS	Top Slat to Ring
10	802-0031-05	5/16"-18 Square Nut	Top Slat to Ring
10	804-0025-05	5/16" Flat Washer	Top Slat to Ring
1	806-0071-05	Rivet, Rnd Hd, 1/2" x 1-3/4"	AW to Bracket

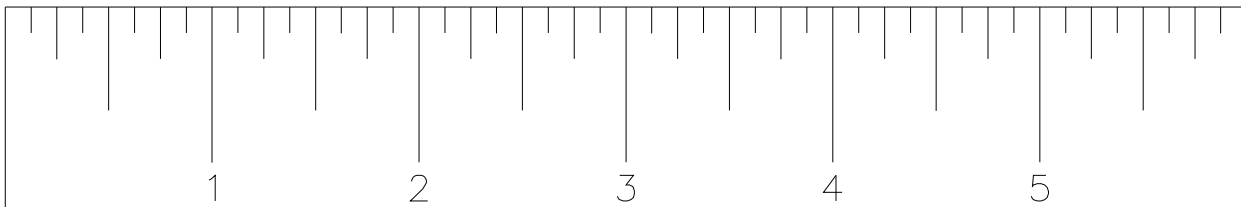

Step 1: Opening Checks

Obtain installation drawing from the hardware bag. Check opening width "A" and opening height "B" or "F" to be sure the opening is correct for the door size. Any slight variations in actual opening width or height, or plumbness of the jambs can be disregarded when installing the guides. Verify that the clearances available meet or exceed those given on the installation drawing.

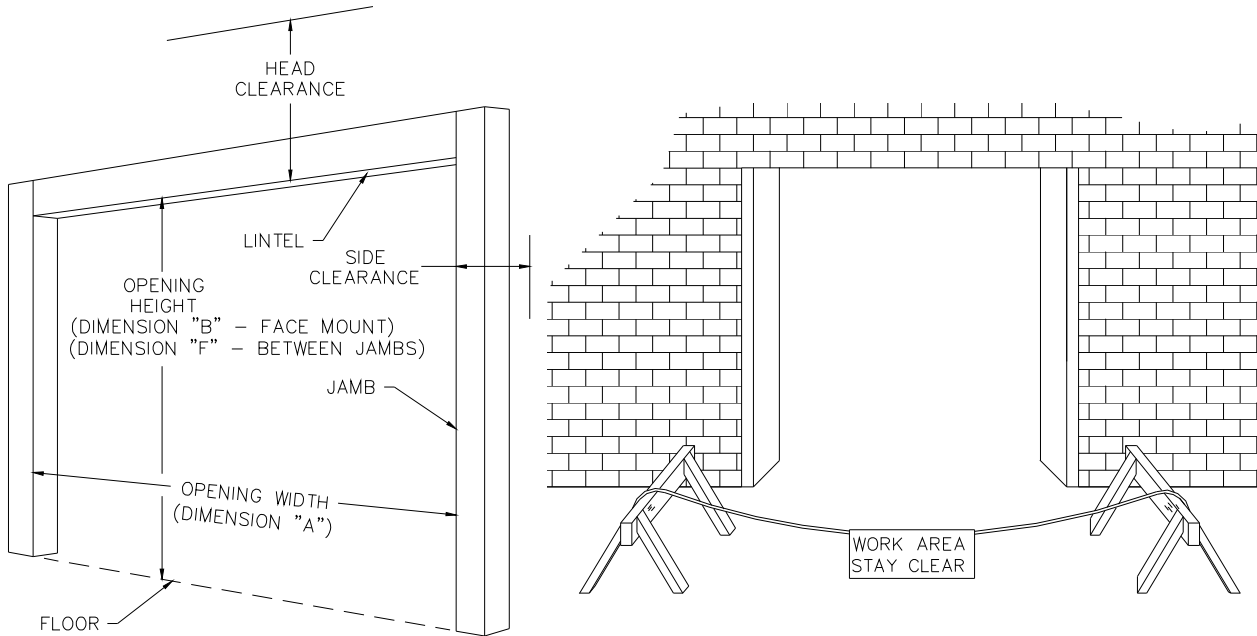

WARNING

To avoid possible injury, keep people and objects clear by roping off the door opening area.

Step 2: Guide Mounting

Face Mounted Doors

Record the "C" dimension from the installation drawing on the line provided below. Measure the distance from the inside of the left guide to the centerline of the slots on the wall angle ("M") and record. Repeat for the right guide. On masonry jambs (with mounting leg out as shown, or "Z" guides), add the "C" dimension and the recorded dimensions ("M") to obtain a "bolt line" dimension (for steel jambs, or "E" guides, subtract).

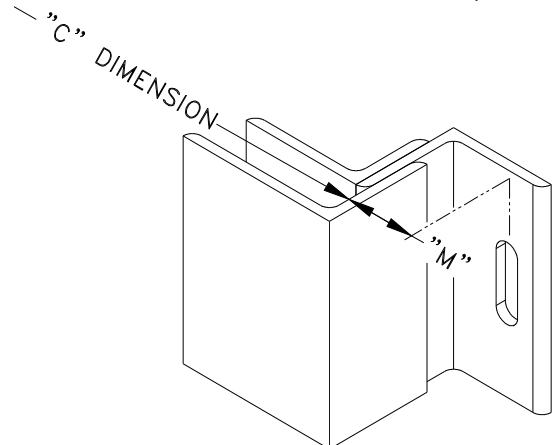

"C" Dimension (from Dwg)	_____
"M" (Left Guide)	_____
"M" (Right Guide) (+ Masonry jamb; - Steel jamb)	_____
Bolt line	_____

Center the bolt line dimension in the opening and make a mark on one jamb at the top. Drop a plumb line down and make a second mark on the wall at the bottom. Using a chalk line, make a vertical line the length of the "F" dimension, passing through both marks. Measure "BL" horizontally onto the other jamb and repeat the process.

Measure from the bottom of the mounting angle to the bolt centerline at the bottom of the first slot. Add the expansion clearance (found on the installation drawing) to this dimension and mark that point on the wall.

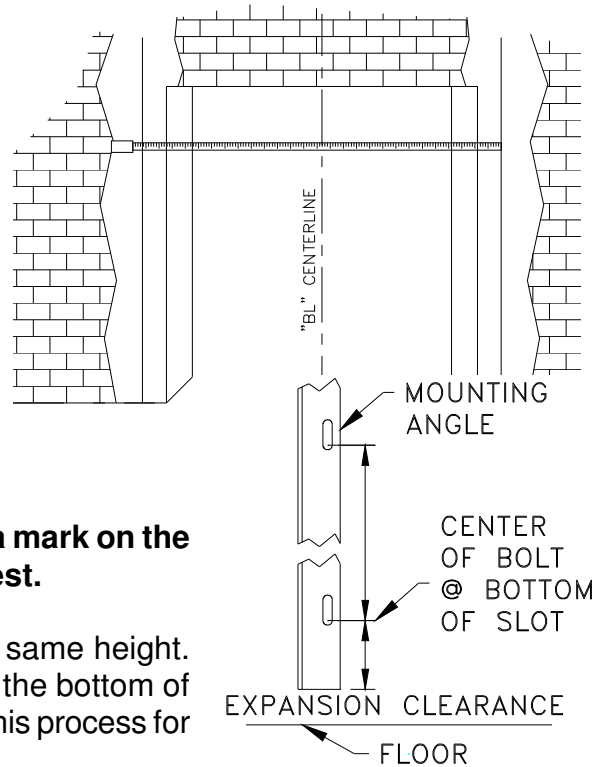

NOTE:

If floor is not level, make a mark on the jamb where floor is highest.

Using a string level, mark the other jamb at the same height. Measure from this point to the bolt centerline at the bottom of the next slot up on the mounting angle. Repeat this process for the remaining holes.

NOTE:

On steel jambs where guides are going to be welded in place, measure to the last (top) slot.

Next, drill the appropriate size holes for the fasteners provided (listed as "Guides to Wall" on hardware shipping list).

IMPORTANT!

IF any fasteners, other than the ones supplied are used, they must be on the approved substitution list in NFPA 80 and cannot be of a lesser grade or diameter.

WARNING

Guide assemblies are extremely heavy. To avoid possible injury, persons with lifting limitations should not perform this next step.

Stand up the guide assembly against the wall and install the top and bottom bolts in the slots provided. **Bolts must be installed at the bottom of all slots.** Repeat for other jamb.

IMPORTANT!

The galvanized washers must be installed to ensure proper guide expansion in event of fire.

IMPORTANT!

Fire doors will tend to expand downward. It is necessary to set the guides off the floor the required expansion clearance per the installation drawing provided and install the guide bolts at the bottom of slots.

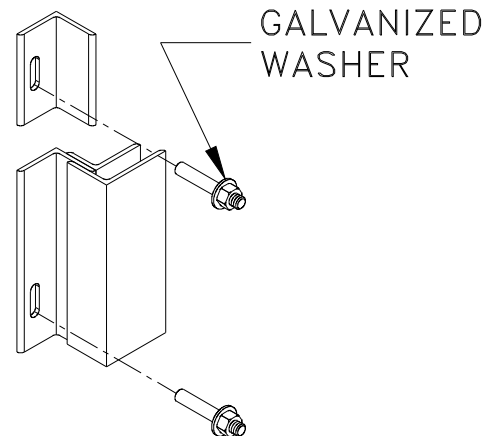

Using a string and a level, ensure that the guides are parallel to each other. Shim at the wall as required. Place the level on both guides. Now install the remaining bolts (for welding of guides see next page). Install the back bottom bar stops now (see Step #9).



APPLICABLE JAMBS

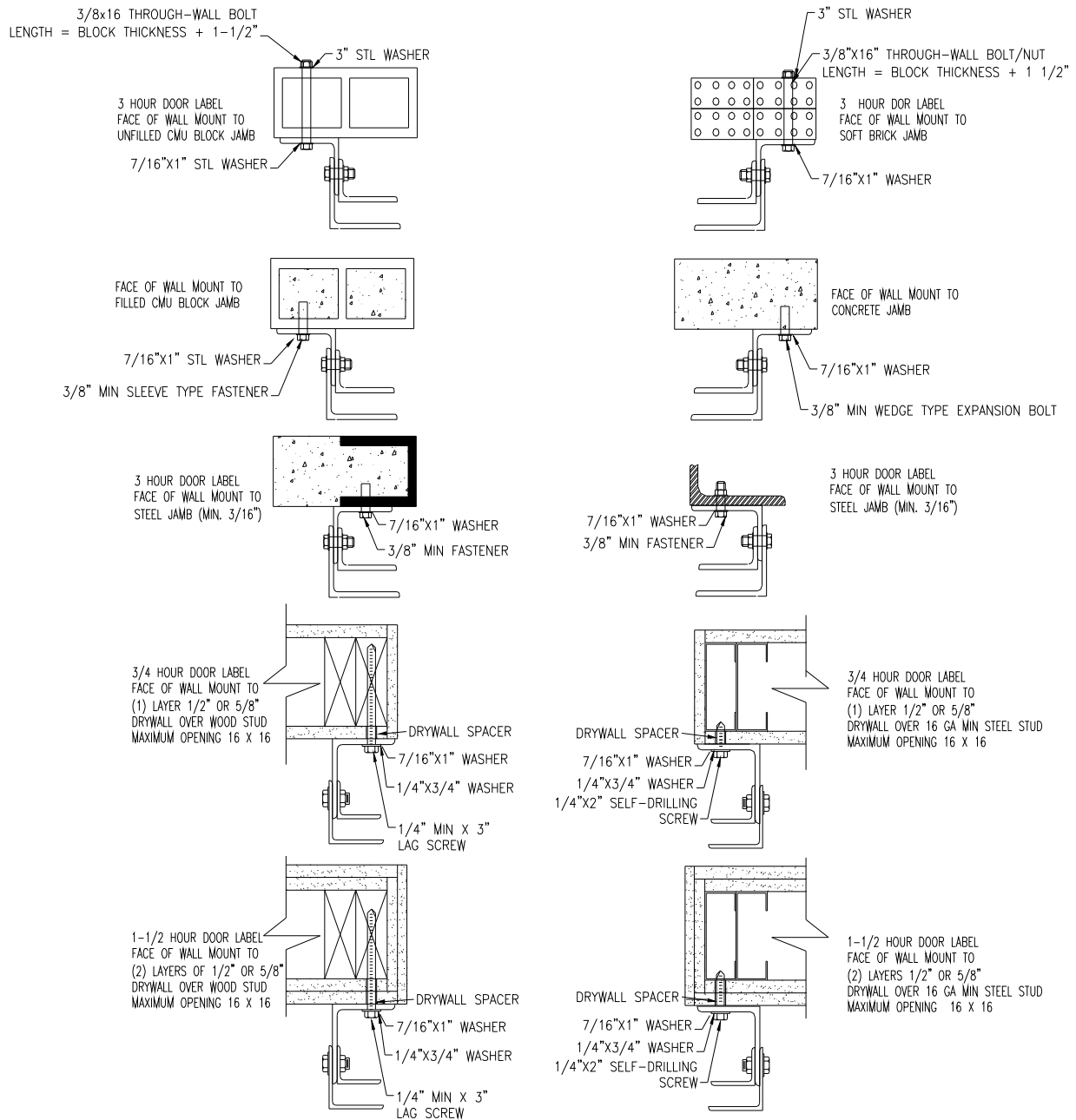

Alternate Welding of Guides to Steel

Welding the guides to steel jambs is an approved method of installation, providing it is done according to the following instructions.

NOTE:

Welding of guides is approved for UL rated fire doors only.
Welding of guides is NOT approved for FM rated fire doors.

IMPORTANT!

The instructions below must be followed closely.
Failure to do so may cause door to be inoperative or fail in event of a fire.

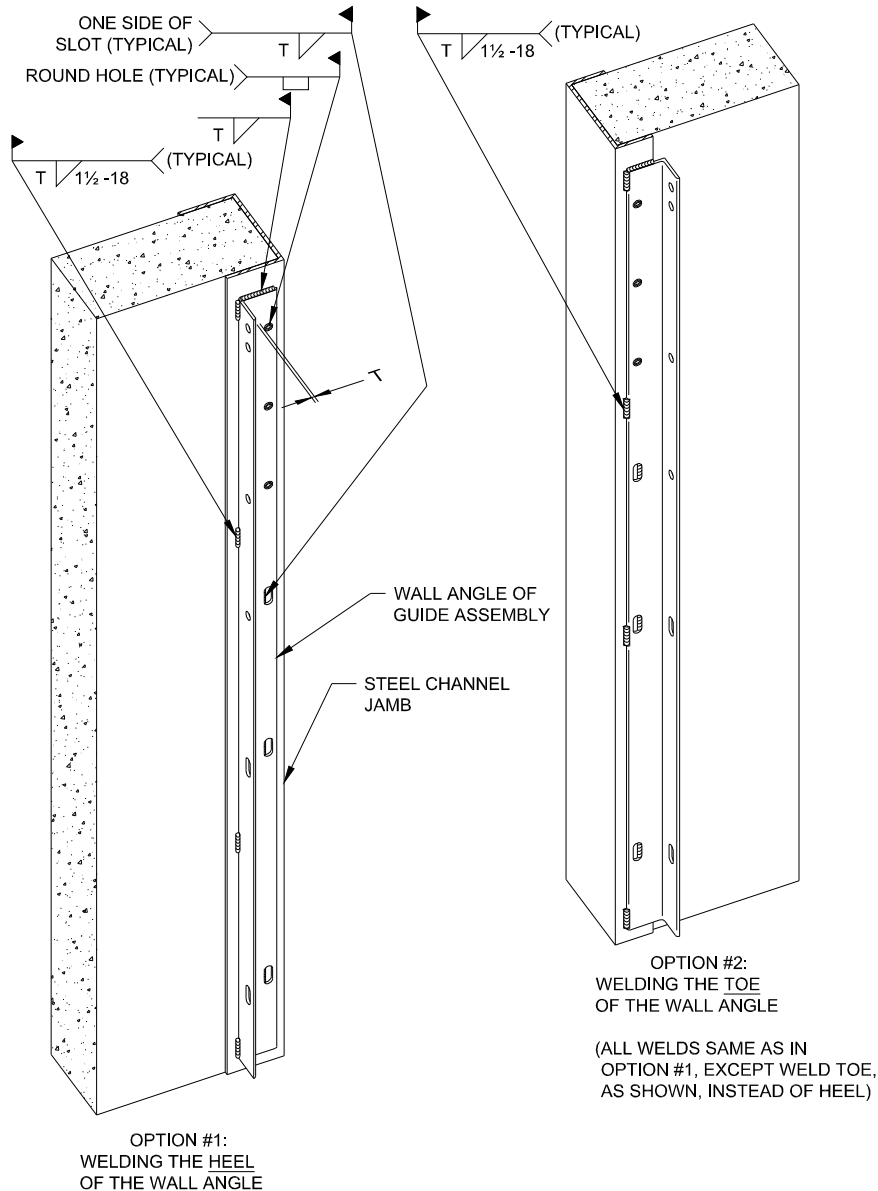

Use E6010/E6011 electrodes or electrodes of equivalent strength. All welding must be done "vertical up" (i.e. starting the individual weld bead and welding upwards). Use fillet welds based on the information provided above.

Between Jamb Mounted Doors

Unbolt the fourth angle (sometimes called the "packout" angle) from the three angle guide assembly (if supplied by factory).

NOTE:

Extra angles are seldom the same size (right and left). After being unbolted, they must be re-attached to the correct side. Mark the angle "L" or "R" on the angle leg that mounts to the wall.

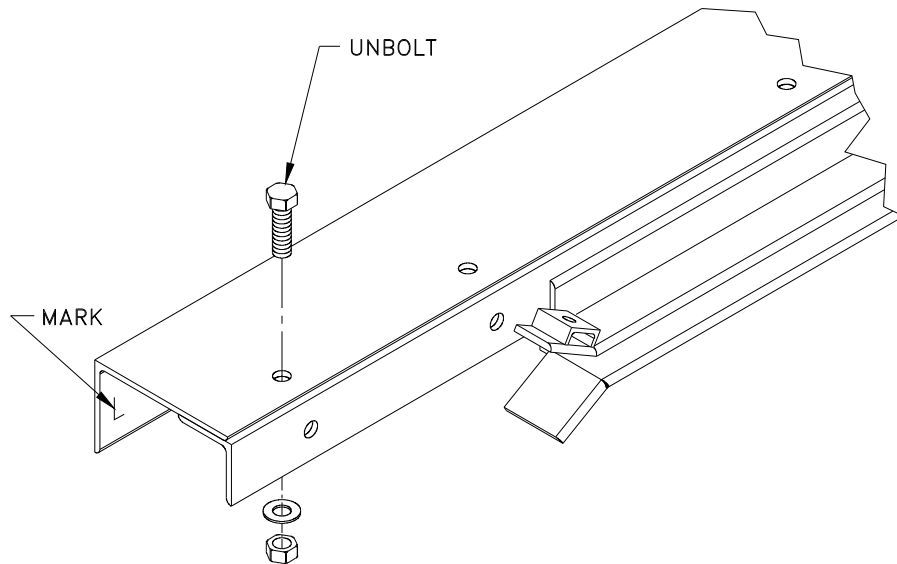

IMPORTANT!

Hardware and bolt spacing requirements are determined by door size. Specific information on proper hardware is located on the hardware bill in hardware bag. Make sure each hole is filled with proper bolts supplied with door.

Guides that mount between the jambs install very similarly to face mounted doors. Follow the steps for face mounted doors except the "wall angle" is now the fourth or "packout" angle. Now reattach the guide assemblies to the packout angles. Next install the back bottom bar stops (see step #9).

NOTE:

Openings are often not square. Hold the "C" dimension and shim packout angle from wall with metal shims as required. Any resulting gaps > 1/4" must be covered with sheet metal.

IMPORTANT!

The galvanized washers must be installed to ensure proper guide expansion in event of fire.

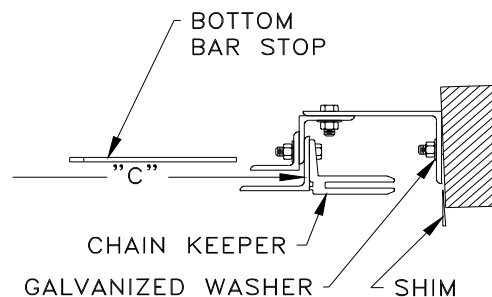

Chain Keeper Mounting

Once guides are completely installed, mount chain keeper on operator side of the door, 3' to 5' above finished floor, using guide assembly bolt. Chain keeper may vary from the one shown.

Step 3: Bracket to Spring Barrel Installation

WARNING

Springs are closer to one side of barrel assembly, causing that side to be heavier. Barrel assembly will fall if lifted from center. To avoid possible severe or fatal injury, carefully determine balance point, prior to lifting barrel assembly, to prevent barrel assembly from falling.

WARNING

Bracket assemblies can be heavy. To avoid possible injury, persons with lifting limitations should not perform this next step.

3a Adjuster Side Bracket:

Be sure to remove the adjusting wheel and any other items temporarily attached to the adjuster side bracket (this is the bracket with the adjusting wheel wired to it) to prevent them from falling. Lift the adjuster side bracket assembly into place, sliding the adjuster side shaft (this is the shaft with the flat on it) into the hole in the bracket assembly. Slide the adjusting wheel onto the flat of the barrel assembly shaft. Install the cotter pin in the shaft outside of the adjusting wheel, or tightly clamp with vise grips.

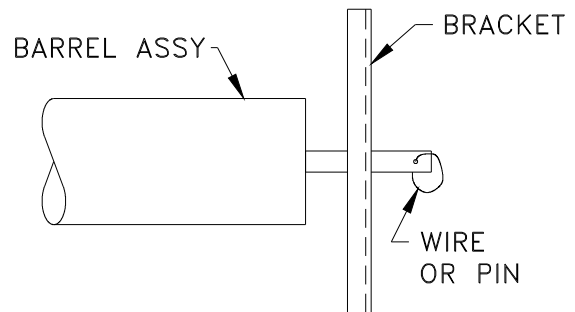

WARNING

Secure bracket to barrel assembly using supplied cotter pin, or vise grips, to prevent it from sliding off during lifting. Failure to secure bracket to barrel assembly could result in severe or fatal injury.

3b Operator Side Bracket:

First remove the stub shaft temporarily attached to the operator side bracket (this will be the one with the drive assembly bolted to it) by loosening the set screws on the drive assembly hub. Discard the stub shaft.

After removing the stub shaft check to make sure that a square key is still visibly in place in the keyway of the drive assembly hub.

This is not to be removed. Lift the operator side bracket assembly into place, sliding the door drive side shaft (this is the shaft with the keyway on it) into the hole in the bracket assembly and carefully align the drive shaft with the key in the drive assembly hub. (Helpful hint: loosen the 3 attaching bolts from the drive assembly to the end bracket.) Slide the bracket assembly on to the door drive shaft until it stops. **BACK THE BRACKET ASSEMBLY OUT ABOUT 1/4". RE-TIGHTEN THE TWO SET SCREWS LOOSENED EARLIER.**

Center the barrel assembly between the two bracket assemblies.

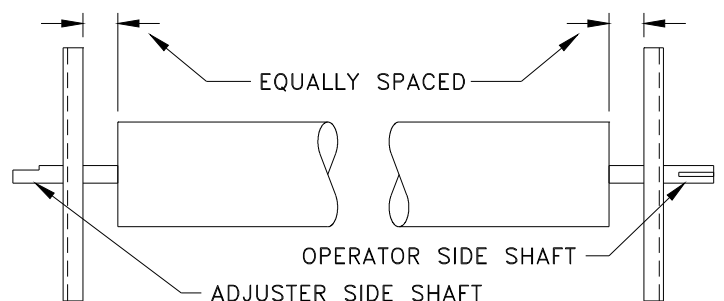
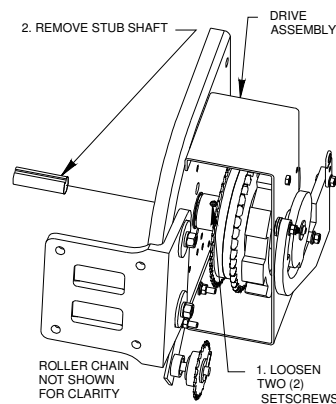

HINT:

Drive assembly can be

removed from bracket if necessary. Loosening the fastening bolts from the drive assembly to the end bracket may ease the installation of the assembly to the drive shaft. Re-tighten after assembly.

Step 4: Barrel Assembly Installation

⚠ WARNING

Secure brackets to barrel assembly to prevent it from sliding off during lifting, possibly causing severe or fatal injury.

Using a chain hoist, fork lift, sling or some means of lifting, determine the balance point of the barrel assembly with the brackets mounted on it.

⚠ WARNING

Springs are closer to one side of barrel assembly, causing that side to be heavier. Barrel assembly will fall if lifted from center. To avoid possible severe or fatal injury, carefully determine balance point, prior to lifting barrel assembly, to prevent barrel assembly from falling.

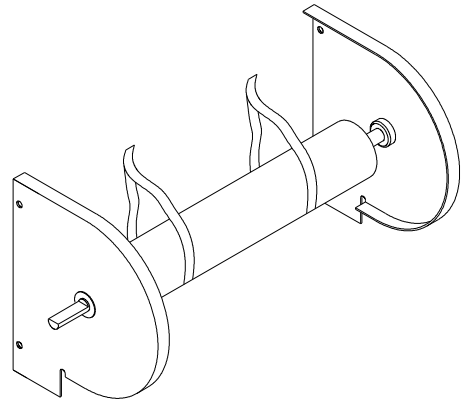

Lift the assembly into place and secure the brackets to the guide wall angles as described below.

NOTE:

Brackets install on side of wall angle away from clear opening.

BRACKET BOLTS
TO THIS SIDE
OF WALL ANGLE

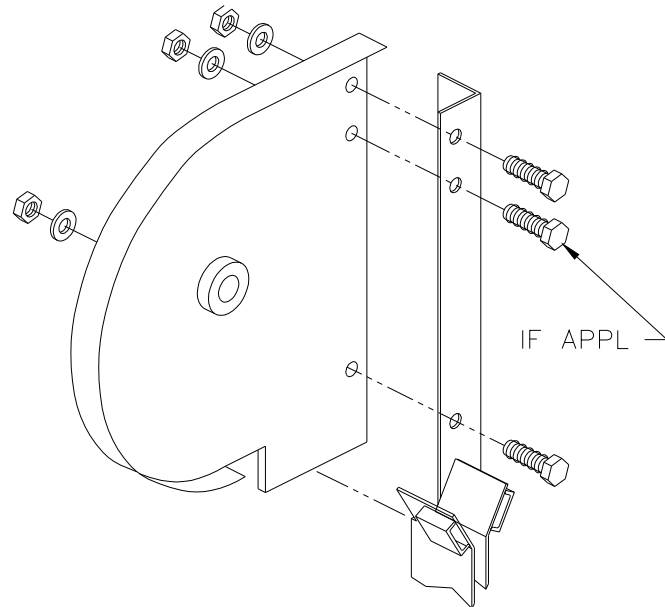
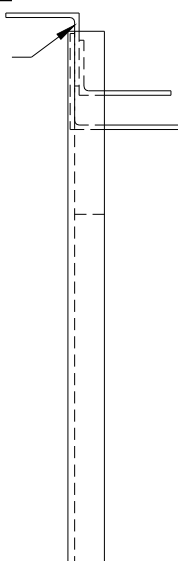

IMPORTANT!

Install bracket bolts from inside so that nuts are on outside of wall angle to keep bolts from interfering with curtain.

Some brackets are symmetrical and therefore have more holes in them than the wall angle.

Doors using the 14" bracket assembly that are less than 13'6" wide and 12' high only require 2 bracket mounting bolts. Refer to your hardware list for fastener quantity.



WARNING

Support barrel assembly until all bracket bolts are installed and secured, otherwise assembly could fall and possibly cause severe or fatal injury.

Step 5: Operator Mechanism Installation

5a Chain Hoist Operator:

Loosen the two (2) bolts fastening the chain hoist support to the bracket. Slide the chain hoist towards the front of the roller chain to increase the tension on the roller chain.

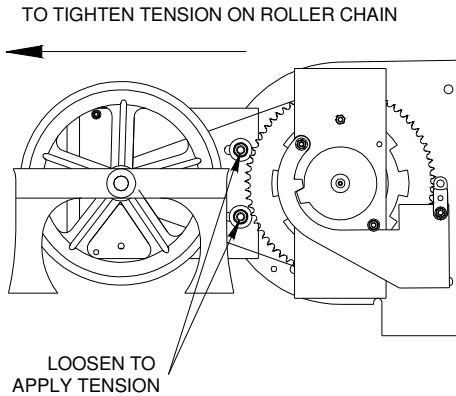

Adjust chain until slack is between 1/4" and 1/2", as shown in the illustration below. If the chain slack exceeds 1/2", re-cut roller chain.

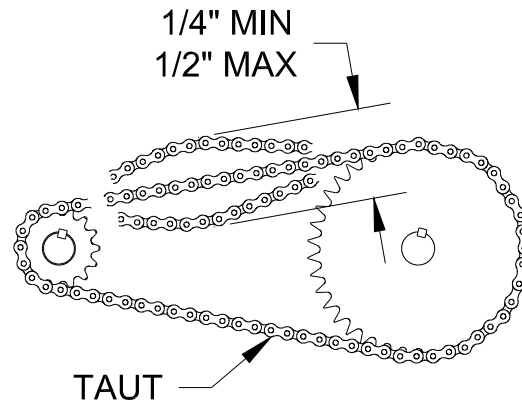

WARNING

Proper installation will result in door being under balanced. Roller chain slack must be less than 1/2" to prevent chain from coming off, allowing door to free fall, possibly causing severe or fatal injury.



IMPORTANT!

Excessively tight roller chain can prevent door from dropping properly during drop test or in case of actual fire.

Be sure to re-tighten the bolts that were loosened earlier.

5b Motor Operator:

Lift and fasten motor operator to support bracket using supplied hardware. Loosen the limit roller chain tension idler sprocket assembly. DO NOT REMOVE THE ASSEMBLY.

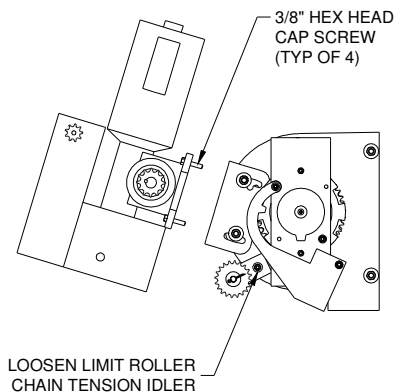

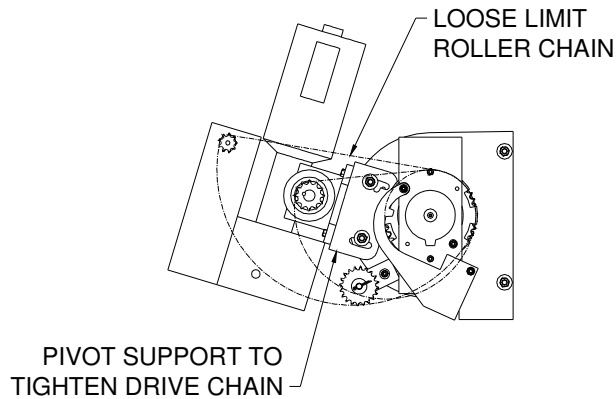

Loop limit roller chain around limit switch sprocket on motor operator and tension idler sprocket on bracket. Do not pull limit roller chain taut at this time. Loop the drive chain around drive sprocket on motor operator.

Loosen top bolt fastening the support to the bracket. Rotate the motor operator and support to tension the drive chain. Tighten the top bolt to fasten support in place. Adjust tension idler assembly to tension the limit roller chain and tighten in place.

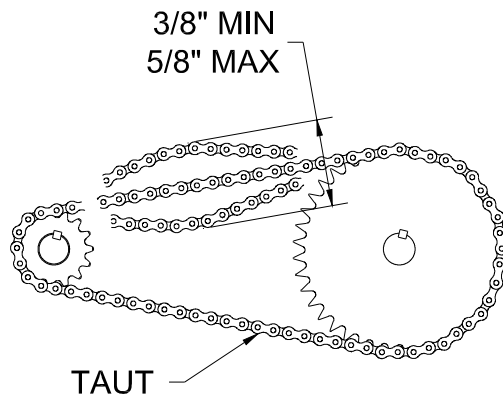
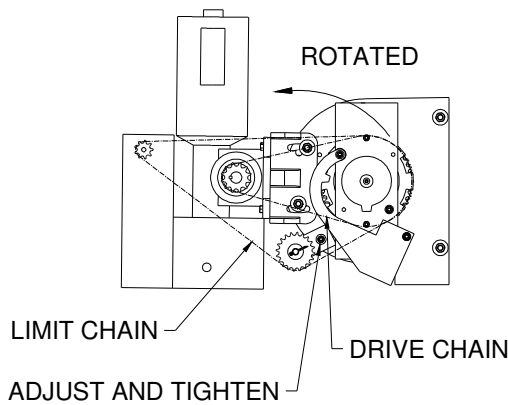

⚠ WARNING

Proper installation will result in door being under balanced. Roller chain slack must be less than 5/8" to prevent chain from coming off, allowing door to free fall, possibly causing severe or fatal injury.

IMPORTANT!

Excessively tight roller chain can prevent door from dropping properly during drop test or in case of actual fire.

Step 6: Curtain Assembly Installation

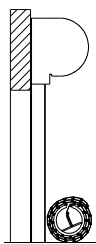

Position the curtain assembly parallel with the door opening so that the top attachment slat is in front of the rest of the curtain (the hinged part away from the opening).

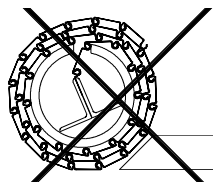

CAUTION

Do not attempt to slide forks of lift truck directly between floor and curtain. Permanent door damage may result.

⚠️ WARNING

Curtain must be securely attached to lifting mechanism. Otherwise, curtain could fall causing possible severe or fatal injury.

Lift curtain assembly (centered between guide assemblies) to approximately one foot below the barrel assembly, using ropes or straps of adequate strength to safely support curtain assembly weight. Remove steel banding from around curtain assembly.

⚠️ WARNING

Banding is under tension.

To avoid possible injury, wear eye protection and do not stand in front of banding when cutting it.

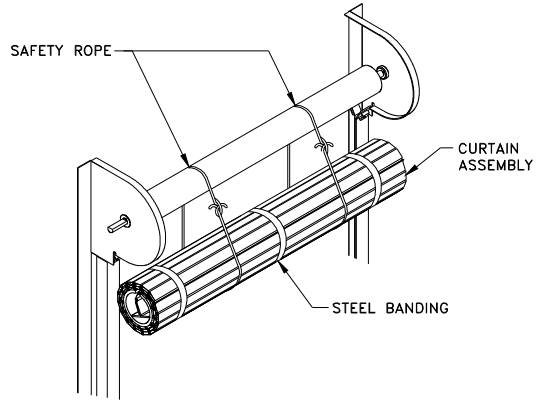

Temporarily engage the drop arm by tying the arm in the engaged position. Using a chain hoist, rotate barrel assembly until top slat attachment point is accessible. Feed top slat around back side of barrel assembly until top slat is out in front of barrel assembly. Install the top slat attachment bolts and nuts, verifying that the curtain is centered between the brackets. Continue rolling the curtain up around the barrel assembly until the entire curtain is coiled onto the barrel assembly. Clamp or block the guide assembly approximately 6" down from the top of the guides. Loosen the safety ropes enough to let the curtain feed into the guide grooves.

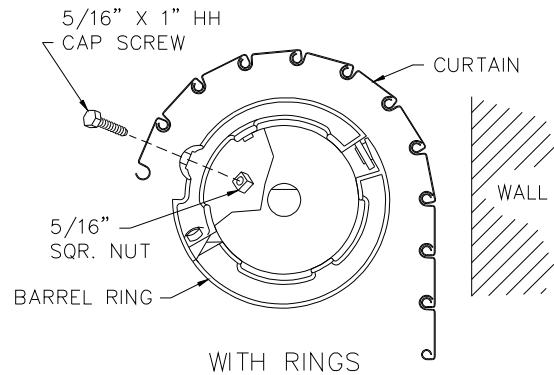
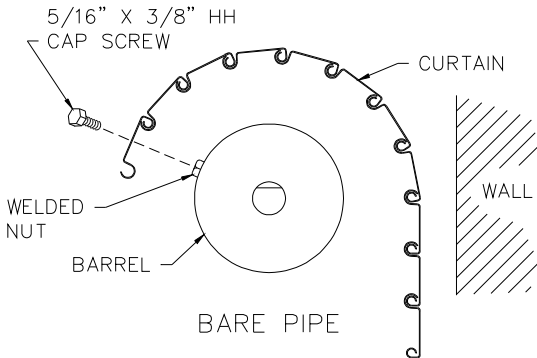

⚠️ WARNING

No tension has yet been applied to door. If curtain is allowed to rotate and free fall, severe or fatal injury could result. Keep the curtain secure and prevent from rotating.

Step 7: Release Handle Mounting

Carefully read the instructions packaged with the release handle assembly. The release handle assembly is designed to be mounted to the wall on the operator side of the door. It is desired to position the release handle assembly in a location that is easily accessible, yet sufficiently out of the way to prevent interference with chain hoist operation. While individual installation locations may vary depending on site conditions, the

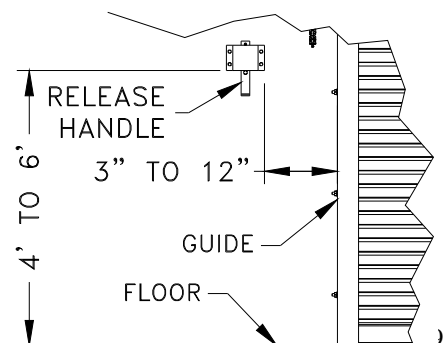

recommended location is shown in the illustration. Determine where the release handle assembly will be installed and attach it to the wall using the fasteners provided. Again, be sure to choose a location that is convenient to operate and will avoid interference with the chain hoist operation and any obstacles that may be in the path of the cable routing.

Step 8: Adjusting Wheel Installation and Tension Application

8a Outside AW:



WARNING

Adjusting wheel holds spring tension. Failure to pin shaft could allow adjusting wheel to fall or door to freefall causing severe injury or death. Verify that cotter pin is installed to retain the adjusting wheel.

Locate the door in the full up position such that the bottom bar is against the bottom bar stops and place a clamp on each guide no more than 6" below the bottom bar. Make certain that the clamping force will be sufficient to stop the door when it rests on the clamps. Carefully lower the curtain so that the bottom bar rest on the clamps. By hand, rotate the adjusting wheel (AW) slightly both directions to determine the neutral point of the spring counterbalance. Mark the hole in the AW that is nearest to the retaining lug on the bracket.

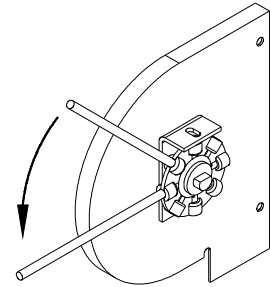

NOTE:

In general, for Firestar™ doors, there is ZERO SPRING TENSION (AFTER FINAL INSTALLATION) when door is fully open.



WARNING

Spring tension increases as door descends, and at its most when door is closed. Always wind spring with door in the fully open position to avoid possible serious injury or death caused by spring tension.

NOTE:

Tension is applied in the direction the coil would turn as the door moves upward.



WARNING

Winding bar must fit snugly into holes in adjusting wheel. Do not use loose fitting bar or screwdriver which could dislodge resulting in possible serious injury or death.

Using approved winding bar (per tool list in front of manual), insert the two rods securely into the holes in the AW as shown. Add tension so that the door slowly rises off the clamps and stops at the bottom bar stops.

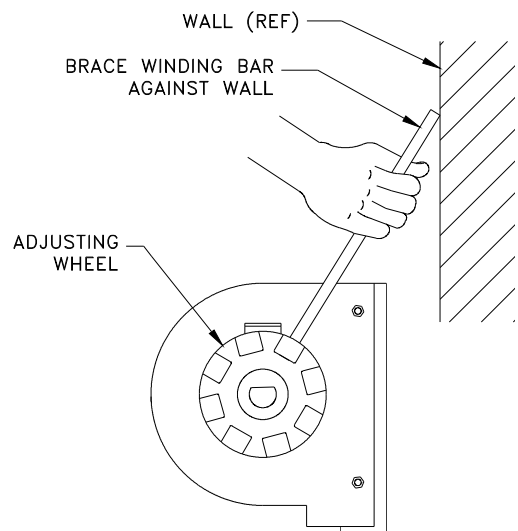

HINT:

If conditions permit, use wall as brace for winding rod for a safe procedure of installing the AW pin as shown.



WARNING

Exercise caution when applying or adjusting spring tension. Contact with rapidly rotating adjusting wheel or expelled winding rod can cause serious

injury or death.

While holding the winding bar firmly in one hand, insert the AW pin with the other hand through the lug in the bracket and into the hole in the AW to lock the AW at the desired number of revs. Remove winding rods.

IMPORTANT!

Door will not function properly if tension is not further adjusted per step #13. Failure to perform step #13 will void the fire rating of this door.

8b Compound AW (sprocket reduction):

See Appendix D, “Compound Tension Adjuster Assembly”, for instructions to wind a compound AW. With the curtain up, wind the initial revs with $\frac{3}{4}$ ” winding bars approximately 36” long by counting the revs of the large sprocket.

Step 9: Bottom Bar Stop Installation

Place two 1/4-20 stud plates through the holes in the flare at the top of the guide as shown. Line up the holes in the bottom bar stop with the studs and assemble using four 1/4-20 flange nuts. Adjust bottom bar stops to obtain maximum contact with bottom bar ensuring bottom bar cannot come out of guides. Tighten flange nuts until secure. Do not over-tighten. Repeat for both flares of both guides.

Prior to Step #10, remove the safety ropes and clamps or blocks at the top of the guides.

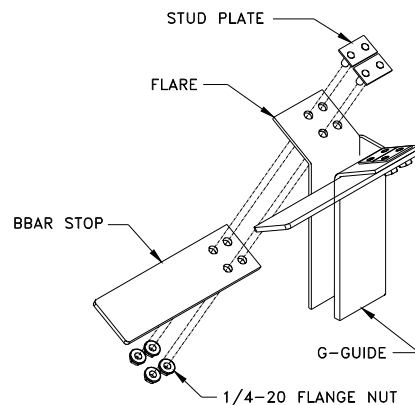

Step 10: Fusible Links and Cable Routing

IMPORTANT!

Secure the door from moving until the fusible link cable routing is complete.

link cable routing is complete.

The fuse cable should route from the end of the Firestar™ drop arm.

Fusible links are designed to melt in the event of a fire and are shipped in the hardware bag. The links must be located in such a way that they will be exposed to any fire that may be inside the building.

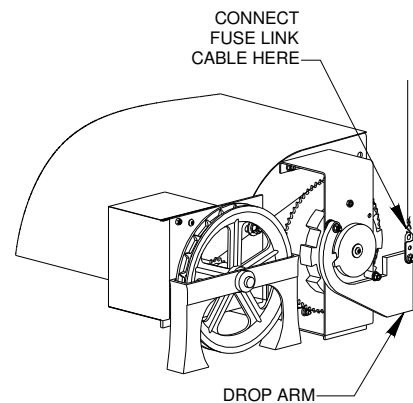

IMPORTANT!

The drop arm on the Firestar™ drive assembly must disengage regardless of which connection in the cable separates.

IMPORTANT!

Per NFPA 80, fusible links must be located 4” to 12” below ceiling on both sides of door opening and near door opening on the side door is mounted.

Standard fuse links are rated 165°F, make sure other fire systems are compatible with this temperature.

Fuse cable routing is to accomplish two tasks. First, the cable routing must position fuse links in the locations specified in NFPA 80. Second, fuse cable must go to the release handle with length such that pulling the release handle down engages the drop arm. The release handle can be kept in down position by using the pin supplied in the hardware bag.

All fusible links must be at least 6" away from any fixed point (ex: pulleys, thru-wall pipe, etc.) or sufficient enough that the drop arm of the drive unit can pivot if any fuse link were to melt. Fuse links are required on coil side of door opening both near the opening and 4" to 12" away from the ceiling. A fuse link is also required on opposite coil side 4" to 12" away from the ceiling. It is recommended that fuse links be located near the opening on both the operator and non-operator sides for doors wider than 15'. Plan cable routing to avoid interference with hood and/or fascia installation described in step #11. If a drive housing and/or adjusting wheel housing has been provided, see Appendix A and plan cable routing to avoid interference with these as well.

Turnbuckles should be used so that cable tension can be fine tuned for operation of the release handle. All turnbuckles should be located high enough that they are out of reach to avoid tampering.

Fuse cable must be vertical when it attaches to the release handle to avoid possible complications with engaging the drive drop arm. Cable routing requires a great deal of

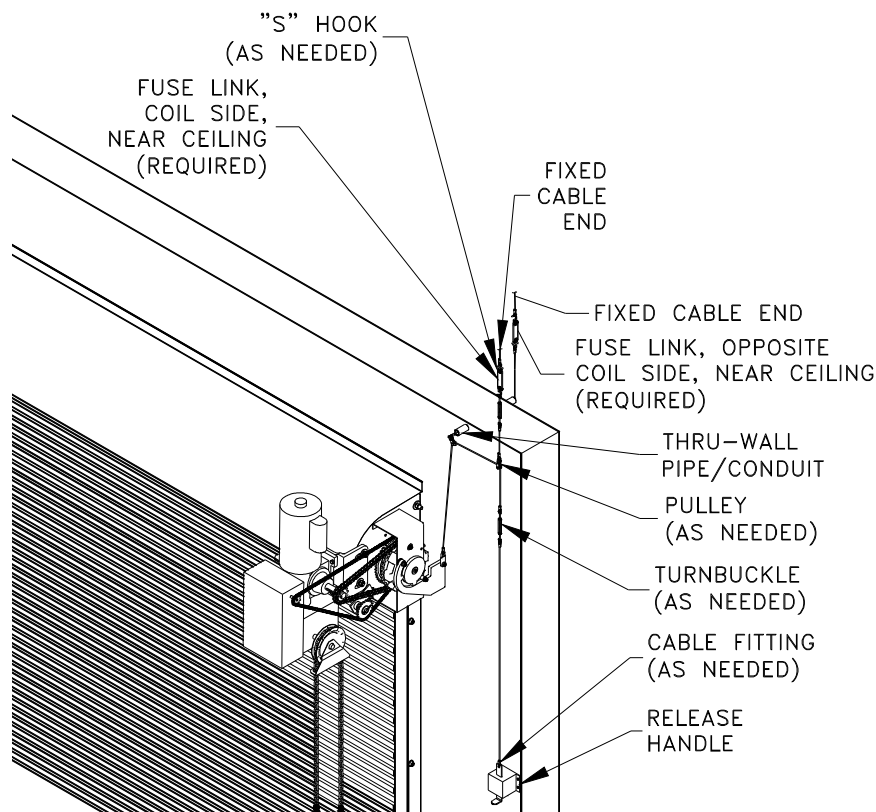

planning and is influenced heavily by field conditions. The illustration represents one possible fuse cable routing approach that meets NFPA 80 requirements. A drawing with additional fuse cable routing illustrations can be found in the hardware bag.

IMPORTANT! NFPA 80 regulations require a fuse link housing to keep the fuse link exposed to the heat of a potential fire, if a drop or false ceiling is installed above the door opening.

In addition to fusible links, some construction codes require that the door(s) be integrated into the building's fire alarm system. This can be accomplished with electro-mechanical release devices such as WayneGuard™. For such devices, see Wayne-Dalton dealer.

Step 11: Hood Installation

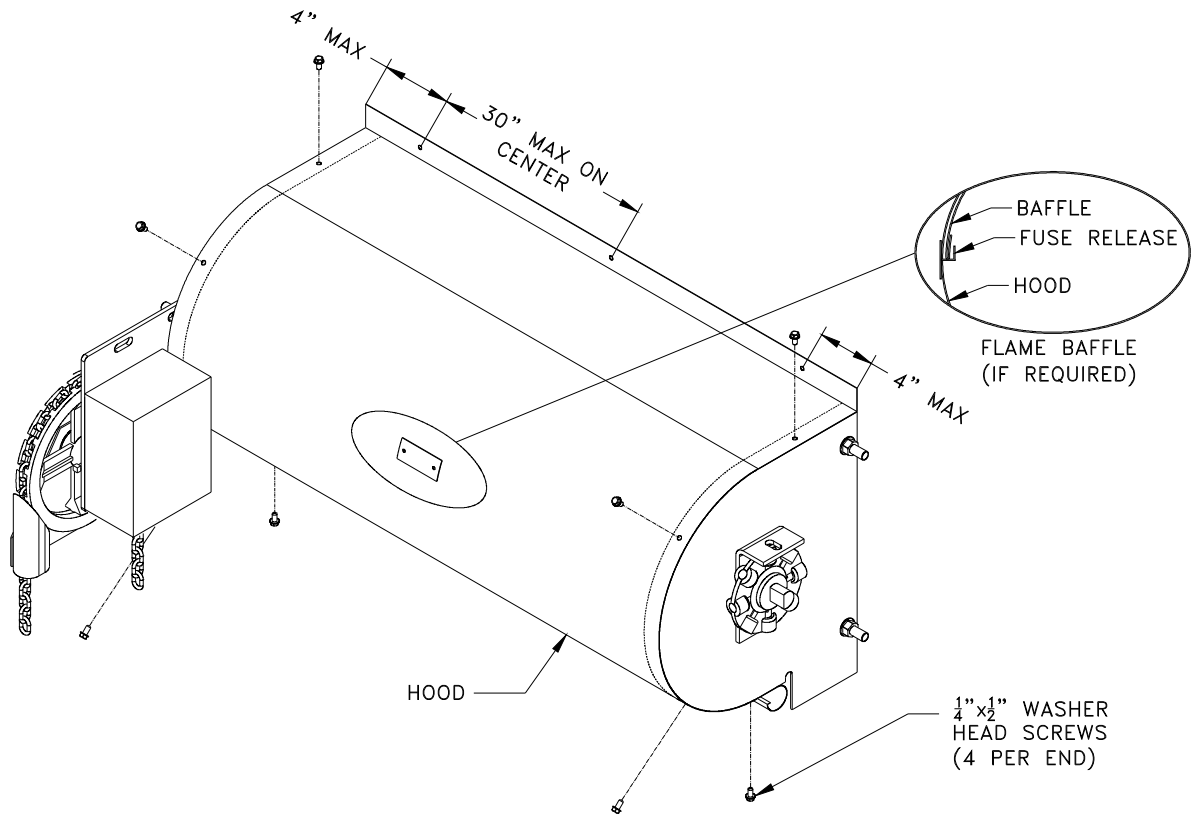

Hoods over 14' long require the use of intermediate support(s). For hoods equipped with a flame baffle, the supports go outside the hood. These are bolted to the hood using screws from the inside of the hood. Raise the front hood and set over the flanges on the bracket assemblies. Fasten hood to brackets using the 1/4" diameter self-tapping washer head screws provided. Fasten hood securely to the wall using the fasteners listed on the hardware bill.

IMPORTANT!

NFPA 80 does not approve the use of lead anchors on rolling fire door installations.

Step 11b: Fascia/Back Hood Installation

Between jamb doors and some face mounted doors often require the use of a fascia on the back of the coil to cover the curtain assembly. Install the fascia onto the outermost angle on between jambs mounted doors and between the wall angle and the wall on face mounted doors. It may be necessary to cut a notch where the top one or two guide bolts are installed.

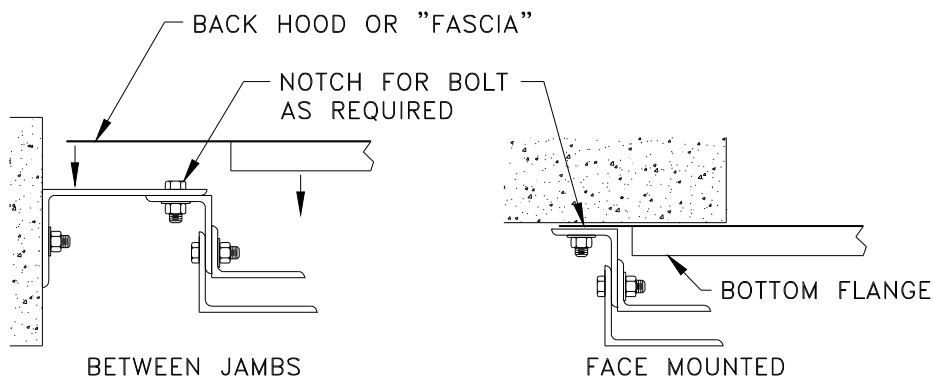

Step 12: Applying Chain Hoist Brake Force

NOTE:

This is a preliminary brake force and should be adjusted per step #13.

Remove brake housing. Tighten the brake lock nut compressing the brake spring down to about 1 inch. Open and close the door making sure the door does not drift at any point through the door's travel. Replace the brake housing after final adjustments are made per step #13.

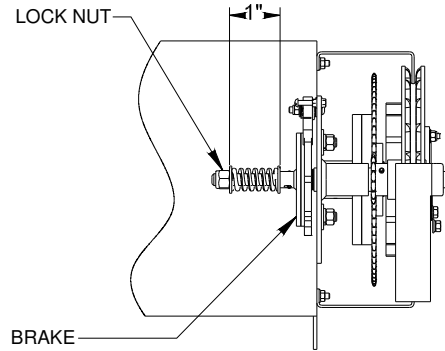

Step 13: Tension Removal and Test Drop Procedure

IMPORTANT!

Failure to perform this step properly and in its entirety will void the fire rating of this door

IMPORTANT!

Secure the hand chain in the chain keeper before all drop tests in case the brake nut is not sufficiently tightened. Failure to perform this step properly and

in its entirety can result in rapid descent of door when operated causing possible serious injury or death.

Locate the door in the full up position such that the bottom bar is resting on the bottom bar stops and place a clamp on each guide no more than 6" below the bottom bar. Make certain that the clamping force will be sufficient to stop the door when it begins to fall. Position the release handle to the "test", or up, position releasing drop arm and disengaging chain hoist. Move the chain of the chain hoist to make sure it is disengaged. Using the tensioning method described in step #8, gradually remove spring tension until door falls to the clamps. Lock tension to the bracket lug using the nearest hole in the adjusting wheel.

WARNING

Adjusting wheel must be pinned to bracket lug regardless of tension amount. Failure to pin adjusting wheel to bracket lug will result in rapid descent of door when operated causing possible serious injury or death.

To re-engage the release handle, gently apply pressure to the handle in the downward direction until the hole in the handle is visible on the bottom side of the handle box. It may be necessary to rotate the hand chain slightly to allow the handle to descend far enough. Insert pad lock or pin through the hole to secure the handle in the operate, or down position.

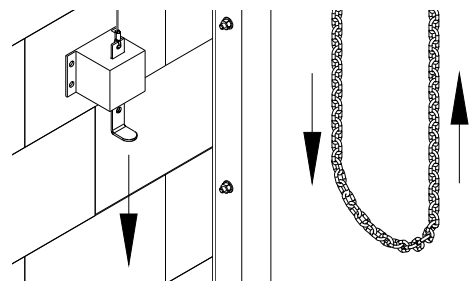

Rotate hand chain to ensure that the drive unit is engaged and that the door is not resting on the clamps. Remove the clamps installed on the guides. Hoist door down and once back up to make certain that door is operating properly.

IMPORTANT!

Prior to dropping, ensure door operates freely and properly in normal operation.

⚠️ WARNING

Door descends rapidly during test procedure. Rope off opening and keep persons from entering area during test drop. Keep all persons clear of opening or serious injury or death could occur. Secure the hand chain in the chain keeper before all drop tests.

⚠️ CAUTION

Keep opening free of objects and debris. Door could strike such objects causing injury or property damage.

With door resting on bottom bar stops, stand clear of the door opening and move the release handle to the test, or up position. If tension is adjusted properly, the door should fall from the bottom bar stops and descend to the closed position. If door does not fall, repeat tension removal procedure. If door falls, re-engage release handle as instructed above and hoist the door to the open position. If door is difficult to hoist, add small amounts of tension and test to make certain that door falls every time.

Once all tension adjustments have been made, hoist door to open position. Release the handle and record the amount of time the door takes to close and verify it falls between 6 and 24 inches per second. If door falls slower than 6 inches per second, remove spring tension per step 8, and recheck descent speed. If door falls faster than 24 inches per second, add spring tension per step 8, and recheck descent speed. Raise door to fully open position several times and repeat drop procedure to verify it is working correctly and consistently. Reengage the release handle and complete the release form provided in the hardware bag and return a copy to the factory.

Once the door has been properly drop tested, the hoist brake should be adjusted so it just barely stops the door at the maximum out of balance to avoid adding excessive effort to close the door. If the door drifts excessively from this position, tighten the brake lock nut a small amount. Retest door operation. If door continues to drift excessively from any location, tighten the nut more. If door does not drift excessively at any location, make sure the nut has not been tightened too much as this will make the door difficult to operate.

Step 14: Miscellaneous Final Checklist

Apply all warning labels in the appropriate locations before leaving the installation site.

Check the area for any extra parts, and be sure these were not omitted in the installation process.

Recheck all bolted connections to verify all are securely tightened.

Clean up the area and make sure it is secure, with the handle engaged with the pin provided.

If the building owner or facility manager is unfamiliar with the product, demonstrate the operation of the door and any optional equipment before leaving the job site. Be sure to

demonstrate how to safely drop test the door and point out the importance of Pad-Locking the release handle to avoid possible tampering.

Have the customer or his representative sign off on the installation using the “Rolling Fire Door Test Drop Release Form” provided in the hardware bag and also fill out the “Test Drop Release Form” in the back of this manual. Return a copy of form in the hardware bag to Wayne-Dalton and keep a copy in your maintenance files. Exchange all documentation and keys to locks at this time. Be sure the customer receives a copy of this manual and of the installation drawing.

Be sure to report (in writing) to the factory any complaints or recommendations the customer may register at the completion of the installation that may have a bearing on future designs.

IMPORTANT! WARNING LABEL MUST BE APPLIED TO OPERATED SIDE OF THE ROLLING DOOR, ON THE GUIDE, 5 FEET ABOVE THE FLOOR.

⚠ WARNING

Moving Door
can cause serious
injury or death.
Do Not start door
downward unless
doorway is clear.



SAFETY INSTRUCTIONS

An overhead door is a large heavy object that moves with the help of springs under high tension. Moving objects and springs under tension can cause serious injuries or death. For your safety and the safety of others, follow these instructions.

1. Unlock door before opening.
2. Door is under high spring tension. If door requires repairs or becomes inoperative, such repairs must be made by an experienced door professional using proper tools and instructions.
3. If door is motor operated and there is no reversing edge, locate control station so that the door is in sight of the user.
4. Operate door only when doorway is in sight and free of people and obstructions.
5. Use both hands to open and close hand chain operated doors. Close door slowly. A runaway door or fast moving chain can cause serious injury.
6. Control crank handle during entire opening or closing of hand crank operated doors. Close door slowly. A runaway door or handle can cause serious injury.
7. DO NOT permit children to operate door or play in or near door area.
8. DO NOT stand in doorway or walk through doorway at any time while door is moving.

800-900 SERVICE DOORS/THERMO-TITE®
TITAN®/SECUR-VENT™/SPARTAN™
GRILLES/SHUTTERS

MAINTENANCE

DETAILED MAINTENANCE INSTRUCTIONS MAY BE FOUND IN THE INSTALLATION INSTRUCTIONS PROVIDED WITH EACH ORDER.

INSPECTION: Visually inspect door every 2 weeks for cleanliness and ease of operation. Check for damage and wear. Tighten bolts wherever needed.

CLEANING: Clean as needed in accordance with good housekeeping practices.

PAINTING: Clean thoroughly with commercial solvents before painting.

CAUTION: Allow paint to dry thoroughly with door in closed position.

LUBRICATION: Necessary only when accumulated dirt and grime are removed. Re-grease lightly. Gear and hoist shafts should be lubricated with machine oil.

TESTING: If door is motor operated and equipped with reversing feature, test such feature monthly for proper operation.

**Rolling Door
Division**

DO NOT remove, cover or paint over this label.
Place label on the drive side guide of rolling door.

97710/01 273491 © Copyright 2001 Wayne-Dalton Corp.

Appendix A: Optional Components

The following are some examples of common options and adjustments for fire doors:

Slide Bolts or Cylinder Locks

Loosen the two screws holding the slipper plate to the guide. Slide the slipper plate to the floor and re-tighten the screws.

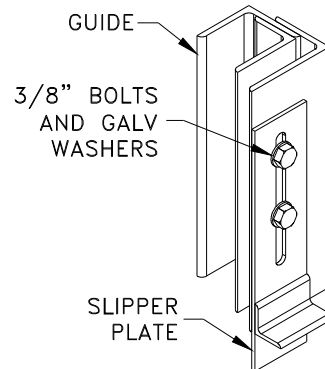

IMPORTANT!

Galvanized washers must be installed to ensure proper guide expansion, allowing door to close in the event of fire.

Operator Housing

Locate the door in the fully closed position. Slide housing over the Firestar™ mechanism as shown. Feed the hand chain through the rectangular cutout in the bottom of the housing. Fasten the housing in place using the fasteners listed on the hardware bill. Make certain that housing is secure and that the fasteners used do not interfere with the safe and proper operation of the door. Field modification of housing may be required to avoid interference with fuse cable routing.

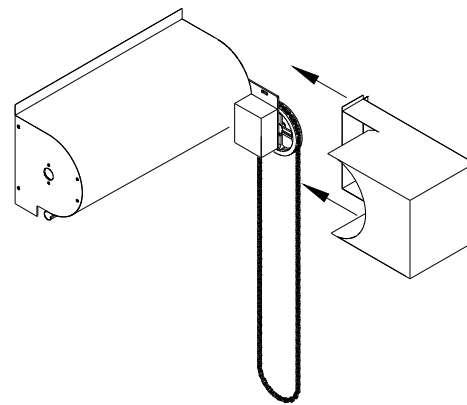

IMPORTANT!

Housing must not interfere with fuse cable. Drop test door after housing installation to verify that door will drop in event of fire.

! WARNING

Housing must be securely fastened in place. Loosely fastened housing could fall causing serious injury or death.

Adjusting Wheel Housing Installation

Locate the door in the fully open position. Remove the hood screws at the adjusting wheel bracket. Slide the adjusting wheel cover over the adjusting wheel. Match drill holes in housing with those in hood and bracket assembly. Attach housing using same screws through both housing and hood.

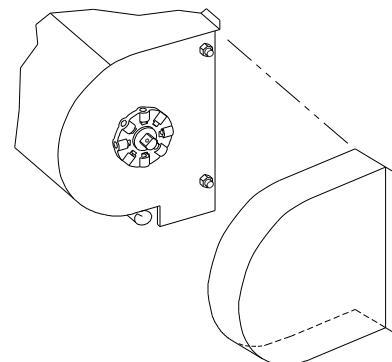

Appendix C: Troubleshooting

The chart below is a list of possible problems with the operation of the fire door. The possible causes listed are the most common, and are not meant to include all possibilities. With the variety of the product and the field conditions, other factors may be involved. If assistance beyond this troubleshooting chart is needed, please contact your Wayne-Dalton dealer. Factory support is available to them, should it be necessary, in order to resolve your problem.

TROUBLE	POSSIBLE CAUSE	REMEDY
Door drops very slow during test	*Roller chain is too tight *Too much spring tension *Binding of door	*Verify roller chain slack is within limits defined in step #5 *Remove spring tension as instructed in step #13 *Check for binding/ interference and correct
Door drops too fast during test	*Too little spring tension	*Add spring tension per step #13 & #8
Door does not drop during test	*Too much spring tension	*Remove spring tension as instructed in step #13
Curtain runs to one side	*Broken endlocks *Barrel not level	*Check and replace *Check and level barrel
Door sticks when closing	*Bent guide angle(s)	*Inspect for bent or kinked guides. *Straighten guides and check width of groove.
Door coil makes cracking sound	*Bent slats	*Inspect, remove and straighten or replace
Door squeaks when operating	*Tight guides *Dirty guides	*Check alignment and distance between guides. *Inspect and clean inside of guide. Do not lubricate with grease. Use WD-40 or silicone spray.
Door is difficult to raise, will not stay open	*Insufficient Counterbalance *Broken spring	*Increase spring tension and repeat drop test procedure *Remove barrel and replace.
Hand chain moves, door does not operate	*Release arm is disengaged	*Verify release handle is locked down *Increase release cable tension

Appendix D: Compound Tension Adjuster Assembly

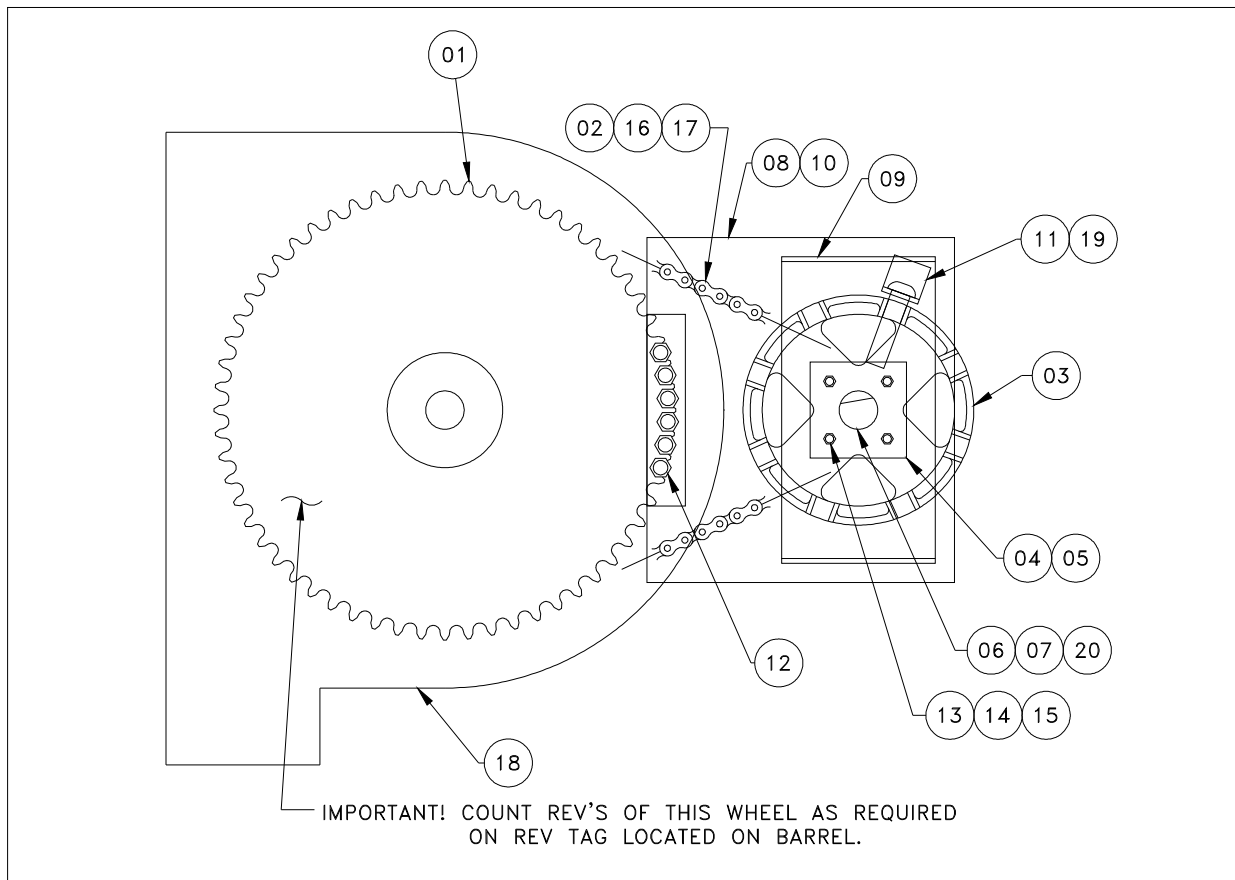

10	1	TENSION HOLDER, 2"x10"x1/2" BAR	20	1	PIN, COTTER, 1/4"x2-1/4", STEEL
09	1	SHAFT SUPPORT PLATE	19	1	RIVET, 3/4"x3-1/2"
08	1	MOUNTING PLATE, 16"x16"x3/8" STEEL	18	1	ADJUSTING BRACKET
07	2	SHAFT COLLAR, 1-1/2" ID	17	AR	ROLLER CHAIN, SERIES AND LENGTH VARY
06	1	SHAFT, 9-1/2"x1-1/2"DIA (C1045)	16	1	KEY, 3/8"x3/8"x1-1/4"
05	2	BEARING, 1-1/2" ID	15	8	NUT, HEX, 3/8-16
04	2	BEARING RETAINER	14	8	WASHER, FLAT, 3/8"
03	1	ADJUSTER: AW745 1-1/2" BORE	13	8	3/8-16 x 1-1/4" HHCS
02	1	SMALL SPROCKET, 13T, 1-1/2" BORE	12	6	TAP BOLT, 1/2-13 x 2-1/2"
01	1	LARGE SPROCKET, (SIZE VARIES)	11	1	CLIP ANGLE, 4"x2"x1/4"x2" LONG
ITEM	QTY	DESCRIPTION	ITEM	QTY	DESCRIPTION

Use bolts (item #12) to lock large sprocket (item #01) into place after applying tension. The amount of initial tension is determined by the revolutions of the large sprocket.



WARNING

Bolts must be in place before door is operated. Roller chain will not hold weight of door. Failure to install all bolts will result in chain breaking, allowing door to fall, causing possible serious injury or death.

ROLLING FIRE DOOR TEST DROP RELEASE FORM

Job Name: _____ Date: _____

WAYNE-DALTON CORP.

CONTRACT NO :

The rolling fire door(s) installed on the above project by _____

_____ have been properly tested in my presence and in accordance with the Wayne-Dalton installation instructions set forth in this manual. The door(s) release automatically and come down to a fully closed position.

Quantity of Firestar™ Fire Doors on this job: _____

Door Mark(s): _____

Tests Performed By:

Tests Witnessed By:

Title: _____

Company: _____

Date: _____

NOTE:

This page is supplemental to the main form, included in the hardware bag. Copies of the main form should be forwarded to the specified locations.

NOTICE

FIRE DOOR PERIODIC TEST REQUIREMENT

This door has been installed and tested for proper operation according to procedures set forth in this manual to ensure that it performs as designed at the time of installation.

Date _____

Installer

Phone

To Possessor of the Premises

The installer has certified that this door has been properly installed, that it has been tested, and that it performs as designed at time of installation. From now on, you should have it inspected regularly and tested periodically for any subsequent damage or wear which might preclude it from closing properly in event of a fire.

Date: _____

Tested By: _____

Fire Marshall

Be aware that the local Fire Marshall is the final authority on the installation and operation of a fire door. He may require steps not listed in NFPA 80 or these instructions.